



# Air Brake Valves

---

- Parts Catalog
- Haldex to Meritor WABCO Cross Reference

# TABLE OF CONTENTS

**MERITOR WABCO**

---

PRODUCTION AND SERVICE .....	i-1
Haldex to Meritor WABCO Cross Reference .....	i-1
CHECK VALVES .....	1
One-Way Check Valves .....	1
Two-Way Check Valves .....	2
DRAIN VALVES .....	4
Drain Valves — Automatic, Heated .....	4
Drain Valves — Automatic, Non-Heated .....	5
Drain Valves — Manual .....	6
FOOT OPERATED VALVES .....	9
Single Circuit Valves .....	9
Dual Circuit Valves .....	10
Single or Dual Circuit Foot Valve and Pedal .....	11
GLADHANDS .....	12
Hose Couplers (Gladhands) Conventional Style .....	12
GOVERNORS .....	14
Piston Type Governor .....	14
HAND OPERATED VALVES .....	16
Trailer Brake Control .....	16
Single Flipper Style Valves .....	19
Double Flipper Style Valves .....	20
Park Brake Valves, 2-Knob .....	21
Park Brake Valves, 1-Knob .....	22
Push-Pull Style Valves .....	23
INVERSION VALVES .....	26
PRESSURE RELIEF VALVES .....	27

# TABLE OF CONTENTS

**MERITOR WABCO**

---

QUICK RELEASE VALVES .....	28
Quick Release Valve with Two-Way Check .....	30
In-Line .....	31
REGULATING VALVES .....	33
Air Regulating Valves .....	33
RELAY VALVES .....	34
Bracket Styles .....	34
RG-2 .....	35
Service .....	36
Service with Optional Top Port Control .....	38
Service with Biased Pressure .....	39
Spring with Double Check Valve .....	40
TRACTOR PROTECTION VALVES .....	42
Tractor Protection Valves Two-Line .....	42
Tractor Protection Valves Two-Line (Manifold Style) .....	43
Tractor Protection Valves Three-Line .....	44
ACCESSORIES — ELECTRICAL .....	45
Electro-Pneumatic Switches .....	45
ACCESSORIES .....	47
Bulkhead Fitting (Frame Nipple) .....	47
In-Line Filters .....	47
Knobs .....	48
ACCESSORIES — TREADLES .....	49
Aluminum Treadles .....	49

# PRODUCTION AND SERVICE

## Meritor WABCO to Haldex Cross Reference

**MERITOR WABCO**

Meritor WABCO		Haldex Brake Systems (Midland)		Description	Page No.
OEM P/N	Service Number	OEM P/N	Service Number		
893 891 003 2	<b>S893 891 003 2</b>			Frame Nipple	47
894 041 605 2	<b>RBE13250</b>	3250	<b>BE13250</b>	Electro-Pneumatic Switch	46
894 041 606 2	<b>R13241A</b>	13241A	<b>BE13241</b>	Electro-Pneumatic Switch	45
894 041 607 2	<b>R325010</b>	325010	<b>325010</b>	Electro-Pneumatic Switch	46
894 041 608 2	<b>RBE13240</b>	13240A	<b>BE13240</b>	Electro-Pneumatic Switch	45
894 041 609 2	<b>RBE13241</b>	1324150	<b>BE13241</b>	Electro-Pneumatic Switch	45
894 041 610 2	<b>RBE13250</b>	325011	<b>BE13250</b>	Electro-Pneumatic Switch	46
894 041 612 2	<b>RBE13255</b>	13255A	<b>BE13255</b>	Electro-Pneumatic Switch	46
894 041 615 2	<b>R1324150</b>	1324150	<b>1324150</b>	Electro-Pneumatic Switch	45
894 041 616 2	<b>R1325550</b>	1325550	<b>1325550</b>	Electro-Pneumatic Switch	46
894 041 619 2	<b>R300629A</b>	300629A	<b>300629A</b>	Electro-Pneumatic Switch	46
894 041 620 2	<b>RBE13255</b>	N15364F	<b>BE13255</b>	Electro-Pneumatic Switch	46
894 041 621 2	<b>RN15364G</b>	N15364G	<b>BE13241</b>	Electro-Pneumatic Switch	45
899 381 282 4	<b>RKN31026</b>	N10083F	<b>KN31026</b>	In-Line Filter	47
899 381 283 4	<b>RN10083K</b>	N10083K	<b>KN31025</b>	In-Line Filter	47
934 099 001 0	<b>RKN23000</b>	N13526AJ	<b>KN23000</b>	One-Way Check Valve	1
934 099 002 0	<b>RKN23060</b>	N13526BL	<b>KN23060</b>	One-Way Check Valve	1
934 099 003 0	<b>RKN25060</b>	N20954A	<b>KN25060</b>	Two-Way Check Valve	3
934 099 004 0	<b>RKN25080</b>	N20966A	<b>KN25080</b>	Two-Way Check Valve	2
934 099 005 0	<b>RKN25090</b>	N20966B	<b>KN25090</b>	Two-Way Check Valve	2
934 099 006 0	<b>RKN25080</b>	N20966E	<b>KN25080</b>	Two-Way Check Valve	2
934 099 007 0	<b>RN20966F</b>	N20966F	<b>KN25110</b>	Two-Way Check Valve	2
934 099 008 0	<b>RKN25100</b>	N20966G	<b>KN25100</b>	Two-Way Check Valve	2
934 099 009 0	<b>RKN25120</b>	N20966J	<b>KN25120</b>	Two-Way Check Valve	2
934 099 010 0	<b>RKN32041</b>	N20952AD	<b>KN32041</b>	Quick Release Valve with Two-Way Check	30
934 099 012 0	<b>RKN25110</b>	N20966R	<b>KN25110</b>	Two-Way Check Valve	2
934 099 013 0	<b>RKN25120</b>	N20966T	<b>KN25120</b>	Two-Way Check Valve	2
934 099 014 0	<b>RKN25060</b>	N20954A	<b>KN25060</b>	Two-Way Check Valve	3
934 099 015 0	<b>RKN32041</b>	N20952AF	<b>KN32041</b>	Quick Release Valve with Two-Way Check	30
934 099 016 0	<b>RKN25120</b>	N20966M	<b>KN25120</b>	Two-Way Check Valve	2

# PRODUCTION AND SERVICE

## Meritor WABCO to Haldex Cross Reference

**MERITOR WABCO**

Meritor WABCO		Haldex Brake Systems (Midland)		Description	Page No.
OEM P/N	Service Number	OEM P/N	Service Number		
934 099 020 0	RKN32041	N20952AE	KN32041	Quick Release Valve with Two-Way Check	30
934 099 021 0	RKN25110	N20966C	KN25110	Two-Way Check Valve	2
934 099 024 0	RKN32040	N20952AB	KN32040	Quick Release Valve with Two-Way Check	30
934 099 025 0	RKN25061	N20966BA	KN25061	Two-Way Check Valve	2
934 099 026 0	RKN32043	N20952BA	KN32043	Quick Release Valve with Two-Way Check	30
934 190 002 0	RKN20001	N13440DA	KN20001	Single Flipper Style Valve	19
934 190 003 0	RKN20001	N13440DB	KN20001	Single Flipper Style Valve	19
934 190 004 0	RKN20001	N13440DC	KN20001	Single Flipper Style Valve	19
934 190 005 0	RKN20041	N13440DD	KN20041	Single Flipper Style Valve	19
934 190 006 0	RKN20041	N13440DJ	KN20001	Single Flipper Style Valve	19
934 190 007 0	RKN20001	N13440DL	KN20001	Single Flipper Style Valve	19
934 190 008 0	RKN20080	N15791D	KN20080	Double Flipper Style Valve	20
934 190 009 0	RKN20090	N15791F	KN20090	Double Flipper Style Valve	20
934 190 010 0	RN15791H	N15791H	N15791H	Double Flipper Style Valve	20
934 190 011 0	RN15791T	N15791T	N15791T	Double Flipper Style Valve	20
934 190 012 0	RN15791V	N15791V	N15791V	Double Flipper Style Valve	20
934 190 013 0	RKN20001	RVN13440DL	KN20001	Single Flipper Style Valve	19
934 199 001 0	RKN23000	N13526BK	KN23000	One-Way Check Valve	1
934 199 002 0	RN13526BR	N13526BR	N13526BR	One-Way Check Valve	1
934 199 003 0	RKN23000	N13526H	KN23000	One-Way Check Valve	1
934 199 004 0	RKN23040	N13526J	KN23040	One-Way Check Valve	1
934 199 005 0	RKN23010	N13526BE	KN23010	One-Way Check Valve	1
934 199 006 0	RKN21020	N13526BT	KN21020	One-Way Check Valve	1
934 199 007 0	RKN23010	N13526AG	KN23010	One-Way Check Valve	1
934 199 008 0	RKN23080	N13526D	KN23080	One-Way Check Valve	1
934 199 010 0	RKN23010	N13526BE	KN23010	One-Way Check Valve	1
934 315 001 0	R12110	10719	12110	Manual Drain Valve	7
934 315 002 0	R12102	N3613C	12102	Manual Drain Valve	7
934 315 003 0	R12102	N3613A	12102	Manual Drain Valve	7

# PRODUCTION AND SERVICE

## Meritor WABCO to Haldex Cross Reference

**MERITOR WABCO**

Meritor WABCO		Haldex Brake Systems (Midland)		Description	Page No.
OEM P/N	Service Number	OEM P/N	Service Number		
934 315 004 0	<b>R12105</b>	N3613AD	<b>12105</b>	Manual Drain Valve	7
934 315 005 0	<b>RKN21004</b>	N3613AN	<b>KN21004</b>	Manual Drain Valve	7
934 315 007 0	<b>RKN21008</b>	N3613AZ	<b>KN21008</b>	Manual Drain Valve	7
934 315 008 0	<b>R12103</b>	N3613BC	<b>12103</b>	Manual Drain Valve	7
934 315 010 0	<b>R12102</b>	N3613BJ	<b>12102</b>	Manual Drain Valve	7
934 315 011 0	<b>RKN21004</b>	N3613CD	<b>KN21004</b>	Manual Drain Valve	7
934 315 012 0	<b>RKN21004</b>	N3613CF	<b>KN21004</b>	Manual Drain Valve	7
934 315 014 0	<b>RKN21004</b>	N3613CH	<b>KN21004</b>	Manual Drain Valve	7
934 315 016 0	<b>RKN21022</b>	N3613CR	<b>KN21022</b>	Manual Drain Valve	7
934 315 017 0	<b>RKN21023</b>	N3613CS	<b>KN21023</b>	Manual Drain Valve	7
934 315 018 0	<b>R12103</b>	N3613CT	<b>KN21024</b>	Manual Drain Valve	7
934 315 019 0	<b>R12103</b>	N3613CV	<b>KN21024</b>	Manual Drain Valve	7
934 315 020 0	<b>R12104</b>	N3613CW	<b>KN21026</b>	Manual Drain Valve	7
934 315 021 0	<b>R12102</b>	N3613F	<b>12102</b>	Manual Drain Valve	7
934 315 022 0	<b>R12102</b>	N3613H	<b>12102</b>	Manual Drain Valve	7
934 315 023 0	<b>R12103</b>	N3613J	<b>12103</b>	Manual Drain Valve	7
934 315 024 0	<b>R12103</b>	N3613S	<b>12103</b>	Manual Drain Valve	7
934 315 025 0	<b>R12104</b>	N3613T	<b>12104</b>	Manual Drain Valve	7
934 315 026 0	<b>RKN21004</b>	N3613CB	<b>KN21004</b>	Manual Drain Valve	7
934 315 027 0	<b>RKN21004</b>	N3613CC	<b>KN21004</b>	Manual Drain Valve	7
934 315 028 0	<b>RKN24001</b>	N20879A	<b>KN24001</b>	Automatic, Heated Drain Valve	4
934 315 029 0	<b>R12100</b>	N15841	<b>12100</b>	Manual Drain Valve	7
934 315 030 0	<b>R12102</b>	N3613AG	<b>12102</b>	Manual Drain Valve	7
934 315 032 0	<b>R12102</b>	N3613B	<b>12102</b>	Manual Drain Valve	7
934 315 033 0	<b>RKN21008</b>	N3613BB	<b>KN21008</b>	Manual Drain Valve	7
934 315 034 0	<b>R12102</b>	N3613BF	<b>12102</b>	Manual Drain Valve	8
934 315 035 0	<b>RKN21004</b>	N3613BT	<b>KN21004</b>	Manual Drain Valve	8
934 315 037 0	<b>R12104</b>	N3613Z	<b>12104</b>	Manual Drain Valve	8
934 315 038 0	<b>RKN24001</b>	N20879D	<b>KN24001</b>	Automatic, Heated Drain Valve	4
934 315 039 0	<b>RKN24000</b>	N20878N	<b>KN24000</b>	Automatic, Non-Heated Drain Valve	5

# PRODUCTION AND SERVICE

## Meritor WABCO to Haldex Cross Reference

**MERITOR WABCO**

Meritor WABCO		Haldex Brake Systems (Midland)		Description	Page No.
OEM P/N	Service Number	OEM P/N	Service Number		
934 315 040 0	<b>RKN21004</b>	N3613AS	<b>KN21004</b>	Manual Drain Valve	8
934 315 041 0	<b>R12102</b>	N3613BE	<b>KN21022</b>	Manual Drain Valve	8
934 315 043 0	<b>S 934 315 043 0</b>			Manual Drain Valve	8
934 315 044 0	<b>S 934 315 044 0</b>			Manual Drain Valve	8
934 315 045 0	<b>S 934 315 045 0</b>			Manual Drain Valve	8
934 315 046 0	<b>S 934 315 046 0</b>			Manual Drain Valve	8
934 315 047 0	<b>S 934 315 047 0</b>			Manual Drain Valve	8
934 315 048 0	<b>S 934 315 048 0</b>			Manual Drain Valve	8
934 315 049 0	<b>S 934 315 049 0</b>			Manual Drain Valve	8
934 315 050 0	<b>S 934 315 050 0</b>			Manual Drain Valve	8
934 315 051 0	<b>S 934 315 051 0</b>			Manual Drain Valve	8
934 315 052 0	<b>S 934 315 052 0</b>			Manual Drain Valve	8
934 315 053 0	<b>S 934 315 053 0</b>			Manual Drain Valve	8
934 315 054 0	<b>S 934 315 054 0</b>			Manual Drain Valve	8
934 315 100 0	<b>RA42150</b>	A42150	<b>A42150</b>	Manual Drain Valve	8
934 315 102 0	<b>R12112</b>	10713	<b>12112</b>	Manual Drain Valve	8
934 316 001 0	<b>RKN24000</b>	N20878A	<b>KN24000</b>	Automatic, Non-Heated Drain Valve	5
934 316 002 0	<b>RKN24000</b>	N20878E	<b>KN24000</b>	Automatic, Non-Heated Drain Valve	5
934 316 003 0	<b>RKN24005</b>	N20879DA	<b>KN24005</b>	Automatic, Heated Drain Valve	4
934 316 004 0	<b>RKN24000</b>	N20878B	<b>KN24000</b>	Automatic, Non-Heated Drain Valve	5
934 316 005 0	<b>RKN24000</b>	N20878C	<b>KN24000</b>	Automatic, Non-Heated Drain Valve	5
934 316 006 0	<b>RKN24000</b>	N20878F	<b>KN24000</b>	Automatic, Non-Heated Drain Valve	5
934 316 007 0	<b>RKN24000</b>	N20878K	<b>KN24000</b>	Automatic, Non-Heated Drain Valve	5
934 316 008 0	<b>RKN24001</b>	N20879B	<b>KN24001</b>	Automatic, Heated Drain Valve	4
934 316 009 0	<b>RKN24003</b>	N20879BA	<b>KN24003</b>	Automatic, Heated Drain Valve	4
934 316 010 0	<b>RKN24003</b>	N20879BB	<b>KN24003</b>	Automatic, Heated Drain Valve	4
934 316 011 0	<b>RKN24001</b>	N20879CB	<b>KN24001</b>	Automatic, Heated Drain Valve	4
934 316 012 0	<b>RKN24001</b>	N20879E	<b>KN24001</b>	Automatic, Heated Drain Valve	4
934 316 013 0	<b>RKN24001</b>	N20879H	<b>KN24001</b>	Automatic, Heated Drain Valve	4

# PRODUCTION AND SERVICE

## Meritor WABCO to Haldex Cross Reference

**MERITOR WABCO**

Meritor WABCO		Haldex Brake Systems (Midland)		Description	Page No.
OEM P/N	Service Number	OEM P/N	Service Number		
934 499 001 0	<b>RN15817A</b>	N15817A	<b>RN15817A</b>	Air Regulating Valve	33
934 499 002 0	<b>RKN31050</b>	N15817E	<b>KN31050</b>	Air Regulating Valve	33
934 499 003 0	<b>RKN31050</b>	N15817F	<b>KN31050</b>	Air Regulating Valve	33
934 499 004 0	<b>RKN31060</b>	N15817M	<b>KN31060</b>	Air Regulating Valve	33
934 499 005 0	<b>RKN31060</b>	N15817K	<b>KN31060</b>	Air Regulating Valve	33
934 499 006 0	<b>RN13680BC</b>	N13680BC	<b>N13680BC</b>	Air Regulating Valve	33
934 499 007 0	<b>RKN31082</b>	N13680BK	<b>KN31082</b>	Air Regulating Valve	33
934 499 008 0	<b>RKN31080</b>	N13680BL	<b>KN31080</b>	Air Regulating Valve	33
934 499 009 0	<b>RN13680BZ</b>	N13680BZ	<b>N13680BZ</b>	Air Regulating Valve	33
934 499 010 0	<b>RKN31050</b>	N15817G	<b>KN31050</b>	Air Regulating Valve	33
934 499 012 0	<b>RKN31081</b>	N13680BD	<b>KN31081</b>	Air Regulating Valve	33
934 649 016 0	<b>RKN20010</b>	N14488	<b>KN20010</b>	Push-Pull Style Valve	25
934 649 017 0	<b>RN14488R</b>	N14488R	<b>N14488R</b>	Push-Pull Style Valve	25
934 649 021 0	<b>RKN20615</b>	N4400	<b>KN20615</b>	Park Brake Valve, 2-Knob	21
934 649 022 0	<b>RKN20606</b>	N4400M	<b>KN20606</b>	Park Brake Valve, 2-Knob	21
934 899 002 0	<b>RKN34061</b>	N20949CF	<b>KN34061</b>	Tractor Protection Valves Two-Line	42
934 899 003 0	<b>RKN34110</b>	N30162MA	<b>KN34110</b>	Tractor Protection Valve Two-Line (Manifold Style)	43
934 899 009 0	<b>RKN34110</b>	N30162PA	<b>KN34110</b>	Tractor Protection Valve Two-Line (Manifold Style)	43
934 899 010 0	<b>RKN34130</b>	N30162PC	<b>KN34130</b>	Tractor Protection Valve Two-Line (Manifold Style)	43
934 899 011 0	<b>RKN34060</b>	N20949CA	<b>KN34060</b>	Tractor Protection Valve Two-Line	42
934 899 013 0	<b>RKN20020</b>	N14488AK	<b>KN20020</b>	Push-Pull Style Valve	25
934 899 017 0	<b>RKN34071</b>	N30073GE	<b>KN34071</b>	Tractor Protection Valve Three-Line	44
934 899 020 0	<b>RKN34100</b>	N30162NA	<b>KN34100</b>	Tractor Protection Valve Two-Line (Manifold Style)	43
934 899 022 0	<b>RKN34111</b>	N30162ME	<b>KN34111</b>	Tractor Protection Valve Two-Line (Manifold Style)	43
934 899 025 0	<b>RKN34103</b>	N30162PB	<b>KN34103</b>	Tractor Protection Valve Two-Line (Manifold Style)	43
934 899 028 0	<b>RKN34104</b>	N30162PD	<b>KN34104</b>	Tractor Protection Valve Two-Line (Manifold Style)	43
934 899 030 0	<b>RKN34101</b>	N30162RD	<b>KN34101</b>	Tractor Protection Valve Two-Line (Manifold Style)	43
936 640 012 0	<b>RKN20607</b>	N4400S	<b>KN20607</b>	Park Brake Valve, 2-Knob	21
936 649 001 0	<b>RKN20021</b>	N20960	<b>KN20021</b>	Park Brake Valve, 1-Knob	22
936 649 002 0	<b>RKN20025</b>	N20961	<b>KN20025</b>	Push-Pull Style Valve	23



# PRODUCTION AND SERVICE

## Meritor WABCO to Haldex Cross Reference

**MERITOR WABCO**

Meritor WABCO		Haldex Brake Systems (Midland)		Description	Page No.
OEM P/N	Service Number	OEM P/N	Service Number		
936 649 003 0	<b>RKN20603</b>	N4400G	<b>KN20603</b>	Park Brake Valve, 2-Knob	21
936 649 004 0	<b>RKN20612</b>	N4400A	<b>KN20612</b>	Park Brake Valve, 2-Knob	21
936 649 005 0	<b>RKN20611</b>	N4400B	<b>KN20611</b>	Park Brake Valve, 2-Knob	21
936 649 009 0	<b>RKN20021</b>	N20960	<b>KN20021</b>	Park Brake Valve, 1-Knob	22
936 649 011 0	<b>RKN20608</b>	N4400R	<b>KN20608</b>	Park Brake Valve, 2-Knob	21
936 649 014 0	<b>RN20960A</b>	N20960A	<b>N20960A</b>	Park Brake Valve, 1-Knob	22
936 649 015 0	<b>RKN20035</b>	N20964	<b>KN20035</b>	Push-Pull Style Valve	24
936 649 018 0	<b>RKN20622</b>	N4400BC	<b>KN20622</b>	Park Brake Valve, 2-Knob	21
936 649 026 0	<b>RKN20619</b>	N4400BA	<b>KN20619</b>	Park Brake Valve, 2-Knob	21
936 649 102 0	<b>RKN20624</b>	N4400DC	<b>KN20624</b>	Park Brake Valve, 1-Knob	22
936 649 671 4	<b>R102684A</b>	102684-A	<b>102684-A</b>	Knob	48
936 649 672 4	<b>R1155903</b>	1155903	<b>1155903</b>	Knob	48
936 649 673 4	<b>R12503</b>	12503	<b>1175003</b>	Knob	48
936 649 674 4	<b>R12509</b>	12509	<b>1175013</b>	Knob	48
936 649 678 4	<b>RN15285P</b>	N15285P	<b>N15285P</b>	Knob	48
939 899 029 0	<b>RKN34065</b>	N20949DA	<b>KN34065</b>	Tractor Protection Valve Two-Line	42
952 899 001 0	<b>R11450</b>	N20415MA	<b>11450</b>	Hose Coupler (Gladhand) Conventional Style	13
952 899 002 0	<b>R11460</b>	N20415MB	<b>11460</b>	Hose Coupler (Gladhand) Conventional Style	13
952 899 003 0	<b>R11463</b>	N20415MC	<b>11463</b>	Hose Coupler (Gladhand) Conventional Style	13
952 899 004 0	<b>R11402</b>	N13048	<b>11402</b>	Hose Coupler (Gladhand) Conventional Style	13
952 899 005 0	<b>R11401</b>	N13048A	<b>11401</b>	Hose Coupler (Gladhand) Conventional Style	13
952 899 100 0	<b>R11451</b>	N20415NA	<b>11451</b>	Hose Coupler (Gladhand) Conventional Style	13
952 899 101 0	<b>R11451</b>	N20415ND	<b>11451</b>	Hose Coupler (Gladhand) Conventional Style	13
952 899 200 0	<b>R11452</b>	N20415PA	<b>11452</b>	Hose Coupler (Gladhand) Conventional Style	13
952 899 201 0	<b>R11452</b>	N20415PD	<b>11452</b>	Hose Coupler (Gladhand) Conventional Style	13
952 899 202 0	<b>R11465</b>	N20415NC	<b>11465</b>	Hose Coupler (Gladhand) Conventional Style	13
952 899 203 0	<b>R11464</b>	N20415PC	<b>11464</b>	Hose Coupler (Gladhand) Conventional Style	13
961 799 001 0	<b>RKN20542</b>	N30103BL	<b>KN20542</b>	Trailer Brake Control	16
961 799 002 0	<b>RKN20561</b>	N30161AH	<b>KN20561</b>	Trailer Brake Control	17

# PRODUCTION AND SERVICE

## Meritor WABCO to Haldex Cross Reference

**MERITOR WABCO**

Meritor WABCO		Haldex Brake Systems (Midland)		Description	Page No.
OEM P/N	Service Number	OEM P/N	Service Number		
961 799 003 0	RKN20542	N30103BF	KN20542	Trailer Brake Control	16
961 799 004 0	RKN20542	N30103BH	KN20542	Trailer Brake Control	16
961 799 005 0	RKN20541	N30103BN	KN20541	Trailer Brake Control	16
961 799 006 0	RKN20542	N30103BY	KN20542	Trailer Brake Control	16
961 799 007 0	RKN20545	N30103FC	KN20545	Trailer Brake Control	16
961 799 010 0	RKN20546	N30103BZ	KN20546	Trailer Brake Control	16
961 799 011 0	RKN20580	N30105B	KN20580	Trailer Brake Control	18
961 799 012 0	RKN20590	N30105C	KN20590	Trailer Brake Control	18
961 799 013 0	RKN20581	N30105D	KN20581	Trailer Brake Control	18
961 799 014 0	RN30105H	N30105H	KN20585	Trailer Brake Control	18
961 799 015 0	RN30103FE	N30103FE	N30103FE	Trailer Brake Control	16
961 897 001 0	RKN22100	N20837	KN22100	Single Circuit Foot Valve	9
961 897 002 0	RKN22100	N20837C	KN22100	Single Circuit Foot Valve	9
961 897 003 0	RKN22100	N20837J	KN22100	Single Circuit Foot Valve	9
961 897 004 0	RKN22100	N20837N	KN22100	Single Circuit Foot Valve	9
961 897 005 0	RKN22100	N20837B	KN22100	Single Circuit Foot Valve	9
961 899 001 0	RKN22150	N30099LA	KN22150	Dual Circuit Foot Valve	10
961 899 002 0	RKN22150	N30099LB	KN22150	Dual Circuit Foot Valve	10
961 899 003 0	RKN22151	N30099LJ	KN22151	Dual Circuit Foot Valve	10
961 899 004 0	RKN22600	N30072FA	KN22600	Single or Dual Circuit Foot Valve and Pedal	11
961 899 005 0	RKN22521	N30072HB	KN22521	Single or Dual Circuit Foot Valve and Pedal	11
961 899 006 0	RKN22501	N30072HC	KN22501	Single or Dual Circuit Foot Valve and Pedal	11
961 899 007 0	RKN22508	N30072HD	KN22508	Single or Dual Circuit Foot Valve and Pedal	11
961 899 009 0	RKN22610	N30072FC	KN22610	Single or Dual Circuit Foot Valve and Pedal	11
961 899 011 0	RKN22150	N30099LA	KN22150	Dual Circuit Foot Valve	10
961 899 015 0	RKN22150	N30099LR	KN22150	Dual Circuit Foot Valve	10
961 899 016 0	RKN22150	N30099LS	KN22150	Dual Circuit Foot Valve	10
961 899 710 2	RSN4017E	N30056BX	SN4017E	Aluminum Treadle	49
961 899 711 2	RSN4017A	N30056BL	SN4017A	Aluminum Treadle	49
961 899 712 2	RSN4017A	N30056BR	SN4017A	Aluminum Treadle	49

# PRODUCTION AND SERVICE

## Meritor WABCO to Haldex Cross Reference

**MERITOR WABCO**

Meritor WABCO		Haldex Brake Systems (Midland)		Description	Page No.
OEM P/N	Service Number	OEM P/N	Service Number		
961 899 713 2	<b>RSN4017F</b>	N30056BW	<b>SN4017F</b>	Aluminum Treadle	49
961 899 714 2	<b>RSN4017A</b>	N30056CB	<b>SN4017A</b>	Aluminum Treadle	49
961 899 715 2	<b>RSN21051</b>	N21051	<b>KN21051</b>	Aluminum Treadle	49
961 899 716 2	<b>RN21052</b>	N21052	<b>N21052</b>	Aluminum Treadle	49
961 899 718 2	<b>RSN4017A</b>	N30056BK	<b>SN4017A</b>	Aluminum Treadle	49
963 880 001 0	<b>RKN31300</b>	N1178AB	<b>KN31250</b>	Pressure Relief Valve	27
963 880 003 0	<b>RKN31300</b>	N1178AC	<b>KN31300</b>	Pressure Relief Valve	27
963 880 004 0	<b>RKN31200</b>	N1178BA	<b>KN31200</b>	Pressure Relief Valve	27
963 880 005 0	<b>RKN31250</b>	N1178BB	<b>KN31250</b>	Pressure Relief Valve	27
963 880 006 0	<b>RKN31250</b>	N1178BB	<b>KN31250</b>	Pressure Relief Valve	27
963 880 007 0	<b>RKN31200</b>	N1178BA	<b>KN31200</b>	Pressure Relief Valve	27
963 880 008 0	<b>RKN31200</b>	N1178AA	<b>KN31200</b>	Pressure Relief Valve	27
963 880 010 0	<b>RKN31400</b>	N1178CA	<b>KN31400</b>	Pressure Relief Valve	27
963 800 011 0	<b>S963 880 011 0</b>	—	—	Pressure Relief Valve	27
963 880 012 0	<b>S963 880 012 0</b>	—	—	Pressure Relief Valve	27
963 880 020 0	<b>RKN31528</b>	N1178EC	<b>KN31528</b>	Pressure Relief Valve	27
967 799 015 0	<b>RKN20542</b>	N30103BS	<b>KN20542</b>	Trailer Brake Control	16
967 799 016 0	<b>RKN20541</b>	N30103BC	<b>KN20541</b>	Trailer Brake Control	16
971 899 001 0	<b>RKN28030</b>	N20950AA	<b>KN28030</b>	Inversion Valve	26
971 899 002 0	<b>RKN28032</b>	N20950CA	<b>KN28032</b>	Inversion Valve	26
971 899 004 0	<b>RKN28030</b>	N20950AA	<b>KN28030</b>	Inversion Valve	26
971 899 005 0	<b>RKN28030</b>	N20950AA	<b>KN28030</b>	Inversion Valve	26
971 899 007 0	<b>RKN28033</b>	N20950CD	<b>KN28033</b>	Inversion Valve	26
971 899 008 0	<b>RKN28034</b>	N20950AB	<b>KN28034</b>	Inversion Valve	26
973 298 001 0	<b>RKN28071</b>	N30100AD	<b>KN28071</b>	Spring with Double Check Valve	40
973 298 004 0	<b>RKN28060</b>	N30096F	<b>KN28060</b>	Service Relay Valve	36
973 298 005 0	<b>RKN28061</b>	N30096J	<b>KN28061</b>	Service Relay Valve	36
973 298 006 0	<b>RKN28061</b>	N30096L	<b>KN28061</b>	Service Relay Valve	36
973 298 007 0	<b>RKN28061</b>	N30096M	<b>KN28061</b>	Service Relay Valve	36

# PRODUCTION AND SERVICE

## Meritor WABCO to Haldex Cross Reference

**MERITOR WABCO**

Meritor WABCO		Haldex Brake Systems (Midland)		Description	Page No.
OEM P/N	Service Number	OEM P/N	Service Number		
973 298 008 0	RKN28080	N30096N	KN28080	Service Relay Valve	36
973 298 009 0	RKN28085	N30096P	KN28085	Service Relay Valve	37
973 298 010 0	RKN28300	N30096PA	KN28300	Service Relay Valve	37
973 298 011	RKN28061	N30096T	KN28061	Service Relay Valve	37
973 298 012 0	RN30106C	N30106C	N30106C	Service Relay Valve	37
973 298 013 0	RKN28131	N30106F	KN28131	Service Relay Valve	37
973 298 014 0	RKN28520	N30108AH	KN28520	RG-2 Relay Valve	35
973 298 015 0	RKN28500	N30108BC	KN28500	RG-2 Relay Valve	35
973 298 016 0	RKN28510	N30108BL	KN28510	RG-2 Relay Valve	35
973 298 017 0	RKN27502	N30100LC	KN27502	Spring with Double Check Valve	40
973 298 020 0	RKN28140	N30100AP	KN28140	Service Relay Valve	37
973 298 021 0	RKN28132	N30106D	KN28132	Service Relay Valve	37
973 298 022 0	RKN28500	N30108A	KN28520	RG-2 Relay Valve	35
973 298 031 0	RKN30111	N30111	RN30111	Service with Biased Pressure	39
973 298 032 0	RKN28051	N30111A	KN28051	Service with Biased Pressure	39
973 298 033 0	RKN28051	N30111B	KN28051	Service with Biased Pressure	39
973 298 034 0	RKN28052	N30111C	KN28052	Service with Biased Pressure	39
973 298 035 0	RKN28066	N30100JA	KN28066	Service Relay Valve	37
973 298 036 0	RKN28067	N30100JB	KN28067	Service Relay Valve	37
973 298 037 0	RKN28066	N30100JC	KN28066	Service Relay Valve	37
973 298 038 0	RKN28066	N30100JD	KN28066	Service Relay Valve	37
973 298 040 0	RKN28072	N30100KA	KN28072	Spring with Double Check Valve	40
973 298 041 0	RKN28072	N30100KB	KN28072	Spring with Double Check Valve	40
973 298 042 0	RKN28043	N30100KC	KN28043	Spring with Double Check Valve	40
973 298 043 0	RKN28073	N30100KD	KN28073	Spring with Double Check Valve	40
973 298 044 0	RKN28074	N30100KE	KN28974	Spring with Double Check Valve	40
973 298 045 0	RKN28074	N30100KF	KN28074	Spring with Double Check Valve	41
973 298 046 0	RKN28073	N30100KG	KN28073	Spring with Double Check Valve	41
973 298 047 0	RKN28074	N30100KH	KN28074	Spring with Double Check Valve	41
973 298 048 0	RKN28055	N30111D	KN28055	Service with Biased Pressure	39

# PRODUCTION AND SERVICE

## Meritor WABCO to Haldex Cross Reference

**MERITOR WABCO**

Meritor WABCO		Haldex Brake Systems (Midland)		Description	Page No.
OEM P/N	Service Number	OEM P/N	Service Number		
973 298 050 0	RKN28055	N30111E	KN28055	Service with Biased Pressure	39
973 298 051 0	RKN28086	N30096FA	KN28086	Service Relay Valve	37
973 298 052 0	RKN28087	N30096FB	KN28087	Service Relay Valve	37
973 298 053 0	RKN28088	N30096FC	KN28088	Service Relay Valve	37
973 298 054 0	RKN28089	N30096FD	KN28089	Service Relay Valve	37
973 298 055 0	RKN28041	N30100MA	KN28041	Spring with Double Check Valve	41
973 298 056 0	RKN28085	N30100JE	KN28085	Service Relay Valve	37
973 298 057 0	RKN28053	N30111F	KN28053	Service with Biased Pressure	39
973 298 058 0	RKN28069	N30100MB	KN28069	Spring with Double Check Valve	41
973 298 060 0	RKN28064	N30100JF	KN28064	Service Relay Valve	37
973 298 061 0	RKN28063	N30100MC	KN28063	Spring with Double Check Valve	41
973 898 001 0	RKN28065	N30100AR	KN28065	Service Switch Optional Top Port Control	38
973 898 005 0	RKN28140	N30100AG	KN28140	Service Switch Optional Top Port Control	38
973 898 006 0	RKN28140	N30100HH	KN28071	Spring with Double Check Valve	41
973 899 001 0	RKN32060	N20959DB	KN32060	Quick Release Valve	28
973 899 002 0	RKN32011	N20959EA	KN32011	Quick Release Valve	28
973 899 003 0	RKN32005	N20959EB	KN32005	Quick Release Valve	28
973 899 004 0	RKN32006	N20959HB	KN32006	Quick Release Valve	28
973 899 007 0	RKN32003	N20959HA	KN32003	Quick Release Valve	28
973 899 008 0	RKN32050	N20959DA	KN32050	Quick Release Valve	28
973 899 010 0	RKN32071	N20959LA	KN32071	Quick Release Valve	28
973 899 011 0	RKN32011	N20959MA	KN32011	Quick Release Valve	28
973 899 012 0	RKN32003	N20959HC	KN32003	Quick Release Valve	29
973 899 013 0	RKN32008	N20959ME	KN32008	Quick Release Valve	29
973 899 019 0	RKN32014	N20959MF	KN32014	Quick Release Valve	29
973 899 020 0	RKN32061	N20959NE	KN32061	Quick Release Valve	29
973 899 021 0	RKN32062	N20959NF	KN32062	Quick Release Valve	29
973 899 022 0	RKN32015	N20959MH	KN32015	Quick Release Valve	29

# PRODUCTION AND SERVICE

## Meritor WABCO to Haldex Cross Reference

**MERITOR WABCO**

Meritor WABCO		Haldex Brake Systems (Midland)		Description	Page No.
OEM P/N	Service Number	OEM P/N	Service Number		
973 899 023 0	<b>S973 899 023 0</b>			In-Line Quick Release Valve	32
973 899 024 0	<b>S973 899 024 0</b>			In-Line Quick Release Valve	32
973 899 025 0	<b>S973 899 025 0</b>			In-Line Quick Release Valve	32
973 899 026 0	<b>S973 899 026 0</b>			In-Line Quick Release Valve	32
973 899 027 0	<b>S973 899 027 0</b>			In-Line Quick Release Valve	32
973 899 028 0	<b>S973 899 028 0</b>			In-Line Quick Release Valve	32
973 899 029 0	<b>S973 899 029 0</b>			In-Line Quick Release Valve	32
973 899 030 0	<b>S973 899 030 0</b>			In-Line Quick Release Valve	32
973 899 031 0	<b>S973 899 031 0</b>			In-Line Quick Release Valve	32
973 899 032 0	<b>S973 899 032 0</b>			In-Line Quick Release Valve	32
973 899 033 0	<b>S973 899 033 0</b>			In-Line Quick Release Valve	32
973 899 034 0	<b>S973 899 034 0</b>			In-Line Quick Release Valve	32
973 899 035 0	<b>S973 899 035 0</b>			In-Line Quick Release Valve	32
973 899 036 0	<b>S973 899 036 0</b>			In-Line Quick Release Valve	32
973 899 037 0	<b>S973 899 037 0</b>			In-Line Quick Release Valve	32
973 899 038 0	<b>S973 899 038 0</b>			In-Line Quick Release Valve	32
975 499 001 0	<b>RKN18530</b>	N30190A	<b>KN18530</b>	Piston Type Governor	15
975 499 002 0	<b>RKN18532</b>	N30190AM	<b>KN18530</b>	Piston Type Governor	15
975 499 003 0	<b>RKN18530</b>	N30190C	<b>KN18530</b>	Piston Type Governor	15
975 499 004 0	<b>RKN18531</b>	N30190H	<b>KN18531</b>	Piston Type Governor	15
975 499 005 0	<b>RKN18530</b>	N30190HA	<b>KN18530</b>	Piston Type Governor	15
975 499 006 0	<b>RKN18530</b>	N30190L	<b>KN18530</b>	Piston Type Governor	15
975 499 007 0	<b>RKN18530</b>	N30190GB	<b>KN18530</b>	Piston Type Governor	15
975 499 010 0	<b>RKN18532</b>	N30190AA	<b>KN18532</b>	Piston Type Governor	15
975 499 011 0	<b>RKN18530</b>	N30190AJ	<b>KN18530</b>	Piston Type Governor	15
—	<b>RKN20562</b>	N30161AJ	<b>KN20562</b>	Trailer Brake Control	17

# CHECK VALVES

## One-Way Check Valves

**MERITOR WABCO**

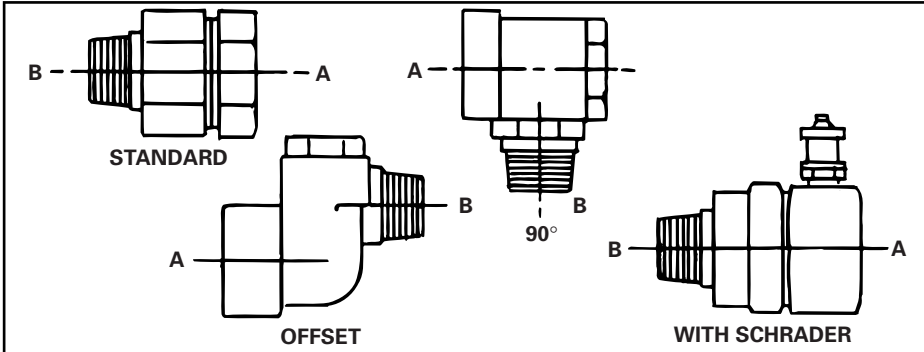
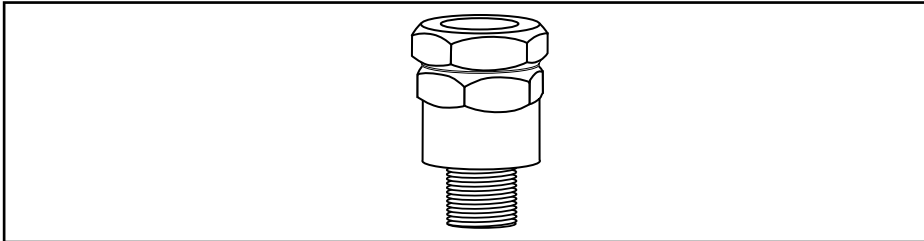

- Used wherever pressures must be isolated and not allowed to back feed.
- Can be used on trucks, tractors and trailers.
- Models listed as heavy duty may be used on compressor discharge.
- Some models are equipped with Schrader valves, used for system checkout.
- All models are male unless otherwise noted.
- All ports are NPTF unless otherwise noted.

Meritor WABCO		Haldex Brake Systems (Midland)		PORTS		LENGTH	WEIGHT	REMARKS
SERVICE P/N	OEM P/N	SERVICE P/N	OEM P/N	A (F)	B (M)			
RKN23000	934 099 001 0	KN23000	N13526AJ	1/2	1/2	2.47	0.8 lbs.	Heavy duty
RKN23060	934 099 002 0	KN23060	N13526BL	1/2	1/2	1.85	0.21 lbs.	Brass — 90° style, sealant on threads
RKN23000	934 199 001 0	KN23000	N13526BK	1/2	1/2			Heavy duty, sealant on threads
RN13526BR	934 199 002 0	N13526BR	N13526BR	1/4	1/4 F			
RKN23000	934 199 003 0	KN23000	N13526H	1/2	1/2			
RKN23040	934 199 004 0	KN23040	N13526J	3/4	3/4	2.31	0.12 lbs.	Standard
RKN23010	934 199 005 0	KN23010	N13526BE	3/8	3/8			
RKN21020	934 199 006 0	KN21020	N13526BT	1/2	1/2			Sealant on threads
RKN23010	934 199 007 0	KN23010	N13526AG	3/8	3/8	2.47	0.8 lbs.	Heavy duty/standard
RKN23080	934 199 008 0	KN23080	N13526D	1/4	1/4 F	1.85	0.12 lbs.	
RKN23010	934 199 010 0	KN23010	N13526BE	3/8	3/8			

F = Female, M = Male

# CHECK VALVES

## Two-Way Check Valves

**MERITOR WABCO**

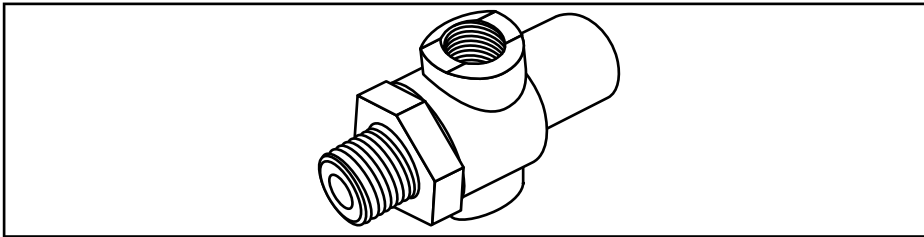

### SHUTTLE TYPE

- Only mount horizontally as pictured.
- For use when two inlets must become one outlet with no communication between inlets.
- Interchangeable with most competitive models.
- All ports are NPTF unless otherwise noted.

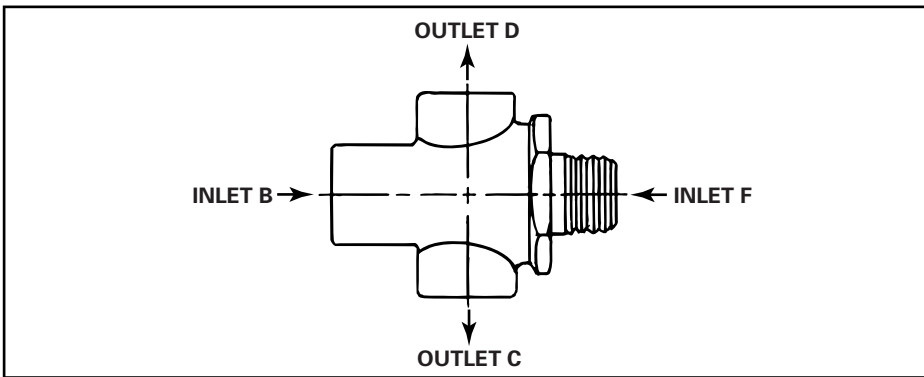

Meritor WABCO		Haldex Brake Systems (Midland)		INLET B	OUTLET C	OUTLET D	INLET F
SERVICE P/N	OEM P/N	SERVICE P/N	OEM P/N				
RKN25080	934 099 004 0	KN25080	N20966A	3/8 F	3/8 F	1/4 F	3/8 M
RKN25090	934 099 005 0	KN25090	N20966B	3/8 F	3/8 F	1/4 F	3/8 F
RKN25080	934 099 006 0	KN25080	N20966E	1/4 M	1/4 F	1/4 F	3/8 M
RN20966F	934 099 007 0	KN25110	N20966F	3/8 F	3/8 F	3/8 F	3/8 F
RKN25100	934 099 008 0	KN25100	N20966G	3/8 F	3/8 F	3/8 F	1/2 M
RKN25120	934 099 009 0	KN25120	N20966J	1/4 F	1/4 F	1/4 F	1/4 F
RKN25110	934 099 012 0	KN25110	N20966R	3/8 M	3/8 F	3/8 F	3/8 F
RKN25120	934 099 013 0	KN25120	N20966T	1/4 F	1/4 F	1/4 F	1/4 F
RKN25120	934 099 016 0	KN25120	N20966M	1/4 F	1/4 F	1/4 F	1/4 F
RKN25110	934 099 021 0	KN25110	N20966C	3/8 F	3/8 F	3/8 F	3/8 F
RKN25061	934 099 025 0	KN25061	N20966BA	3/8	3/8	3/8	(Mtg. Lug)

F = Female, M = Male



# CHECK VALVES

## Two-Way Check Valves

**MERITOR WABCO**

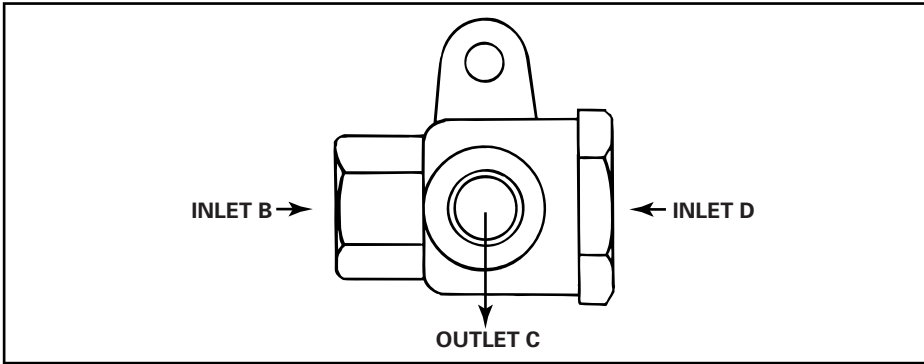
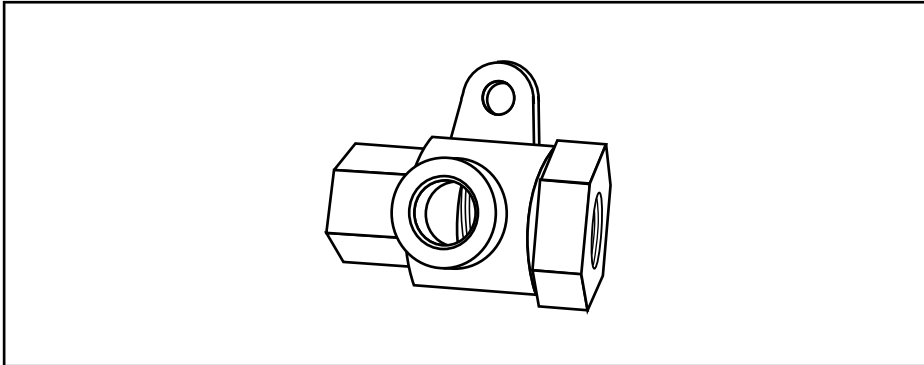

### DIAPHRAGM TYPE

- Not position sensitive, may be mounted in any position.
- Can be used in place of ball or shuttle types.
- Improves FMVSS-121 systems.
- For use when two inlets must become one outlet with no communication between inlets.
- All ports are NPTF unless otherwise noted.

Meritor WABCO		Haldex Brake Systems (Midland)		INLET B	INLET D	OUTLET C
SERVICE P/N	OEM P/N	SERVICE P/N	OEM P/N			
RKN25060	934 099 003 0	KN25060	N20954A	3/8 F	3/8 F	3/8 F
RKN25060	934 099 014 0 *	KN25060	N20954A	3/8 F	3/8 F	3/8 F

F = Female

\* = Volvo application (Volvo Part Number 3082760)

# DRAIN VALVES

## Drain Valves — Automatic, Heated

**MERITOR WABCO**

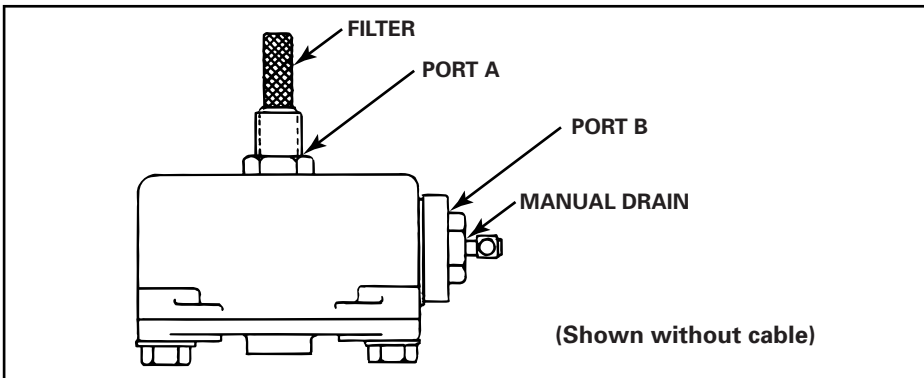
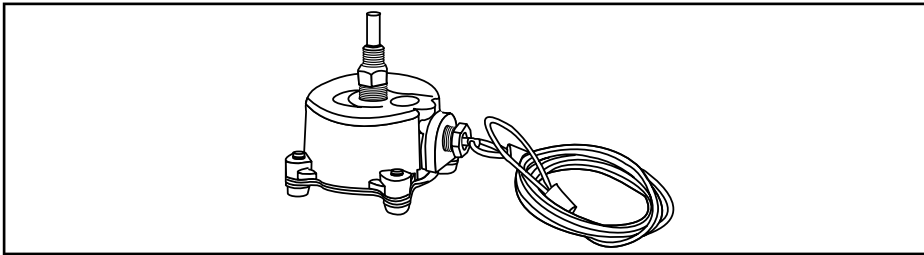

- Heated (12-volt 5 AMP).
- Mounts to bottom of wet tank.
- Exhaust port must be facing down.
- Functions when pressure varies in air tank.
- Only one moving part.
- Cable looped on both ends.
- Direct replacement for DV2.
- All models have 1/4-18 threaded ports.

Meritor WABCO		Haldex Brake Systems (Midland)		MANUAL DRAIN VALVE	CABLE LENGTH	PORT IN WHICH MANUAL DRAIN IS MOUNTED
SERVICE P/N	OEM P/N	SERVICE P/N	OEM P/N			
RKN24001	934 315 028 0	KN24001	N20879A	No	No Cable	No Filter
RKN24001	934 315 038 0	KN24001	N20879D	Yes	7"	A
RKN24005*	934 316 003 0	KN24005	N20879DA	Yes	No Cable	B
RKN24001	934 316 008 0	KN24001	N20879B	Yes	No Cable	B
RKN24003*	934 316 009 0	KN24003	N20879BA	Yes	64"	B
RKN24003*	934 316 010 0	KN24003	N20879BB	Yes	64"	B (No Filter)
RKN24001	934 316 011 0	KN24001	N20879CB	Yes	33"	A
RKN24001	934 316 012 0	KN24001	N20879E	Yes	18.5"	A
RKN24001	934 316 013 0	KN24001	N20879H	Yes	33"	A

\* = Includes Packard connector

# DRAIN VALVES

## Drain Valves — Automatic, Non-Heated

**MERITOR WABCO**

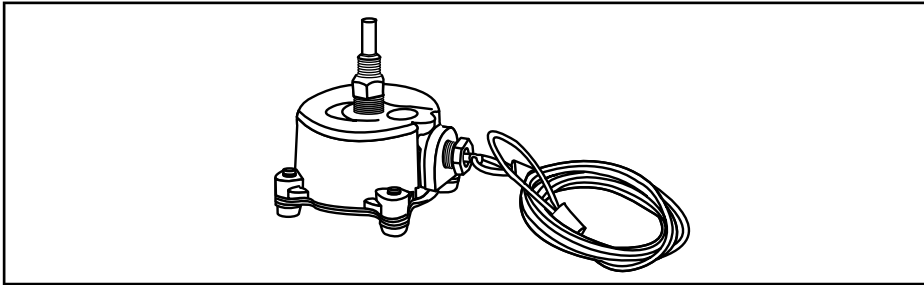

- Non-heated.
- Mounts to bottom of wet tank.
- Functions when pressure varies in air tank.
- Only one moving part.
- Cable looped on both ends.
- Direct replacement for Bendix DV2.

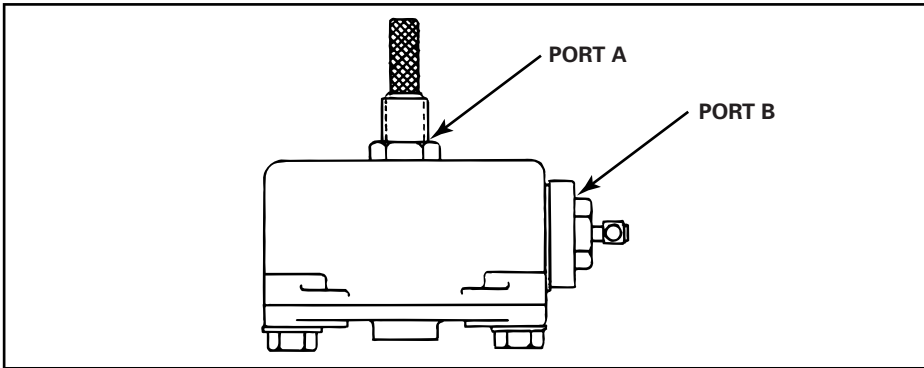

Meritor WABCO		Haldex Brake Systems (Midland)		MANUAL DRAIN VALVE	CABLE LENGTH	PORT IN WHICH MANUAL DRAIN IS MOUNTED
SERVICE P/N	OEM P/N	SERVICE P/N	OEM P/N			
RKN24000	934 315 039 0	KN24000	N20878N	No	No Cable	A
RKN24000	934 316 001 0	KN24000	N20878A	No	No Cable	No Filter
RKN24000	934 316 002 0	KN24000	N20878E	Yes	No Cable	A
RKN24000	934 316 004 0	KN24000	N20878B	Yes	No Cable	B
RKN24000	934 316 005 0	KN24000	N20878C	Yes	36"	B
RKN24000	934 316 006 0	KN24000	N20878F	Yes	18"	A
RKN24000	934 316 007 0	KN24000	N20878K	Yes	No Cable	A

# DRAIN VALVES

## Drain Valves — Manual

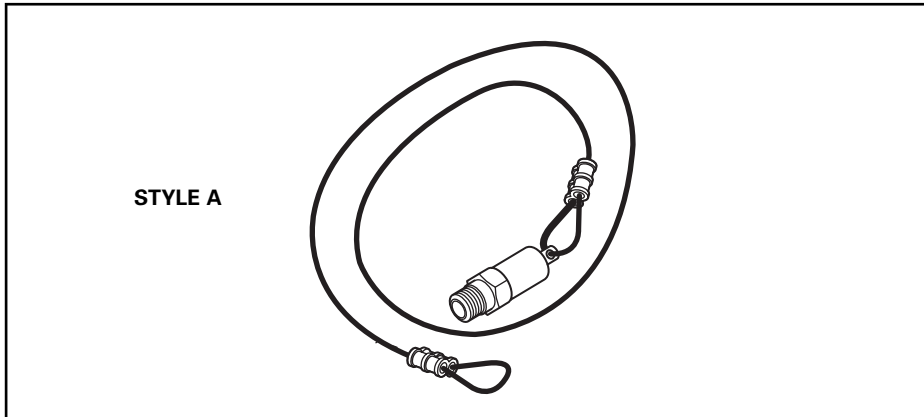

- Manual wet or dry tank drain valves.
- Allows complete draining of reservoirs.
- Cable is looped on both ends for easy hand-hold.
- All models have 1/4-18 thread.
- Weight varies dependent on cable length — see the following chart.
- See pages 7 and 8 for part numbers.

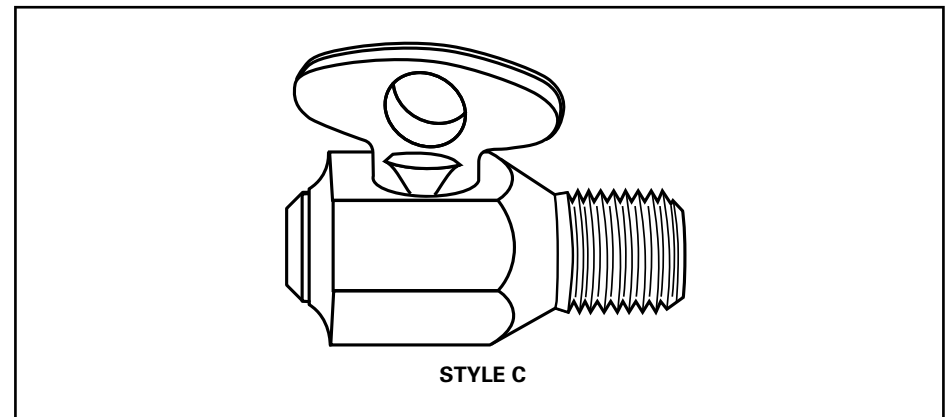
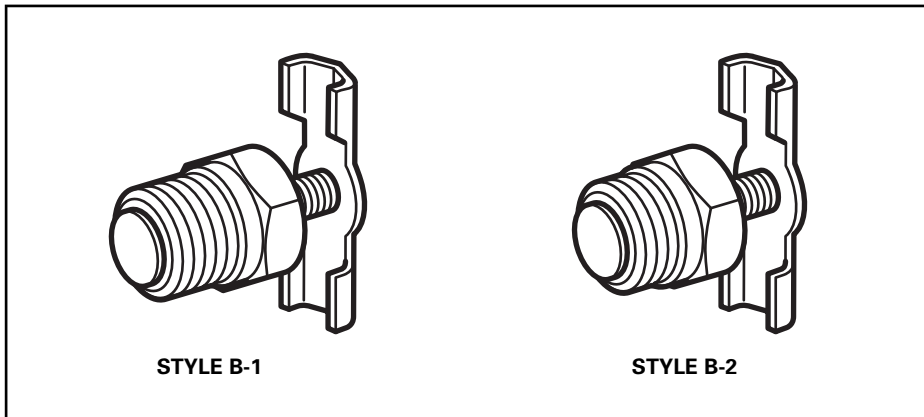

# DRAIN VALVES

## Drain Valves — Manual

**MERITOR WABCO**

Meritor WABCO		Haldex Brake Systems (Midland)		CABLE LENGTH	DRAIN VALVE STYLE
SERVICE P/N	OEM P/N	SERVICE P/N	OEM P/N		
R12110	934 315 001 0	12110	10719	—	C 1/4 Pipe Thread
R12102	934 315 002 0	12102	N3613C	18"	A
R12102	934 315 003 0	12102	N3613A	7"	A
R12105	934 315 004 0	12105	N3613AD	60"	A
RKN21004	934 315 005 0	KN21004	N3613AN	32"	A
RKN21008	934 315 007 0	KN21008	N3613AZ	73.5"	A
R12103	934 315 008 0	12103	N3613BC	34"	A
R12102	934 315 010 0	12102	N3613BJ	10"	A
RKN21004	934 315 011 0	KN21004	N3613CD	48"	A
RKN21004	934 315 012 0	KN21004	N3613CF	19"	A
RKN21004	934 315 014 0	KN21004	N3613CH	14"	A
RKN21022	934 315 016 0	KN21022	N3613CR	12"	A
RKN21023	934 315 017 0	KN21023	N3613CS	20"	A
R12103	934 315 018 0	KN21024	N3613CT	30"	A
R12103	934 315 019 0	KN21024	N3613CV	32"	A
R12104	934 315 020 0	KN21026	N3613CW	38"	A
R12102	934 315 021 0	12102	N3613F	22"	A
R12102	934 315 022 0	12102	N3613H	24"	A
R12103	934 315 023 0	12103	N3613J	25"	A
R12103	934 315 024 0	12103	N3613S	36"	A
R12104	934 315 025 0	12104	N3613T	42"	A
RKN21004	934 315 026 0	KN21004	N3613CB	24"	A
RKN21004	934 315 027 0	KN21004	N3613CC	36"	A
R12100	934 315 029 0	12100	N15841	No Cable	A
R12102	934 315 030 0	12102	N3613AG	76"	A
R12102	934 315 032 0	12102	N3613B	14"	A
RKN21008	934 315 033 0	KN21008	N3613BB	97.5"	A

(continued)

# DRAIN VALVES

## Drain Valves — Manual

**MERITOR WABCO**

(continued)

Meritor WABCO		Haldex Brake Systems (Midland)		CABLE LENGTH	DRAIN VALVE STYLE
SERVICE P/N	OEM P/N	SERVICE P/N	OEM P/N		
R12102	934 315 034 0	12102	N3613BF	16"	A
RKN21004	934 315 035 0	KN21004	N3613BT	48"	A
R12104	934 315 037 0	12104	N3613Z	48"	A
RKN21004	934 315 040 0	KN21004	N3613AS	38"	A
R12102	934 315 041 0	KN21022	N3613BE	2.94" dia.	A
S 934 315 043 0	934 315 043 0			12"	A
S 934 315 044 0	934 315 044 0			14"	A
S 934 315 045 0	934 315 045 0			19"	A
S 934 315 046 0	934 315 046 0			20"	A
S 934 315 047 0	934 315 047 0			24"	A
S 934 315 048 0	934 315 048 0			30"	A
S 934 315 049 0	934 315 049 0			32"	A
S 934 315 050 0	934 315 050 0			36"	A
S 934 315 051 0	934 315 051 0			38"	A
S 934 315 052 0	934 315 052 0			48"	A
S 934 315 053 0	934 315 053 0			60"	A
S 934 315 054 0	934 315 054 0			2.94" dia.	—
RA42150	934 315 100 0	AD42150	A42150	—	B-1 1/8 Pipe Thread
R12112	934 315 102 0	12112	10713	—	B-2 1/4 Pipe Thread

# FOOT OPERATED VALVES

## Single Circuit Valves

**MERITOR WABCO**

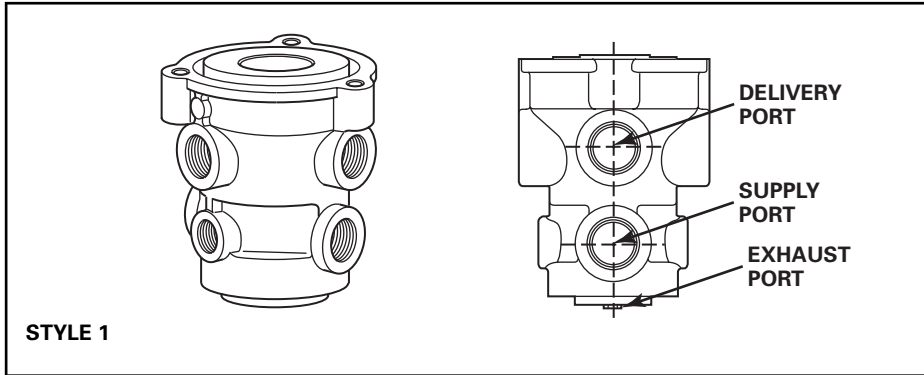

- Provides smooth, consistent pedal feel over competitive application valves.
- Popular changeover valve, requiring minimal modifications.
- Direct replacement for E-3 valve.
- Primary application: Pre-FMVSS121 and off-highway vehicles.
- Delivery ports: (2) 1/2 NPTF Valve Styles 1 and 2  
(2) 1/4 NPTF Valve Styles 1 and 2  
(4) 3/8 Valve Style 3
- Supply ports: (2) 1/2 NPTF Valve Styles 1, 2 and 3  
(2) 1/4 NPTF Valve Styles 1, 2 and 3

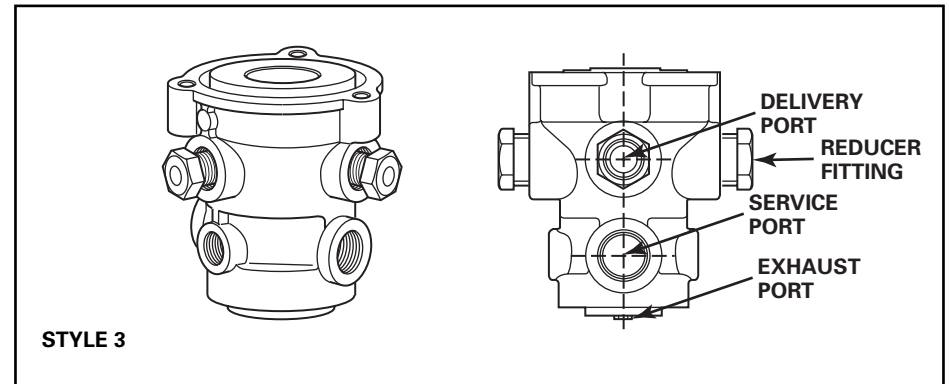
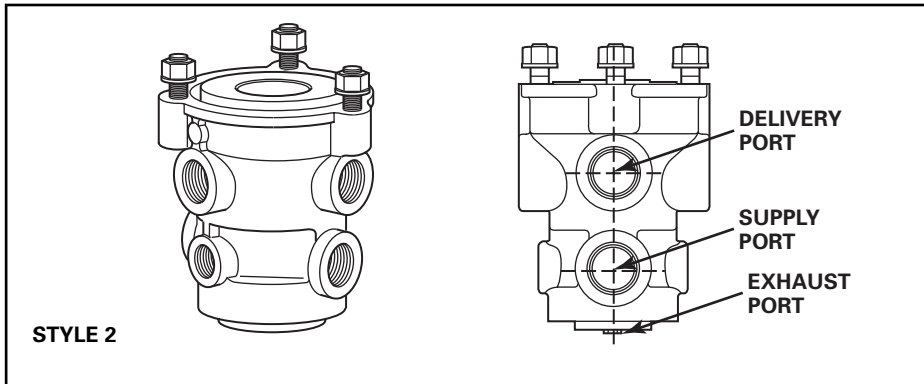

Meritor WABCO		Haldex Brake Systems (Midland)		VALVE STYLE
SERVICE P/N	OEM P/N	SERVICE P/N	OEM P/N	
RKN22100	961 897 001 0	KN22100	N20837	1
RKN22100	961 897 002 0	KN22100	N20837C	1
RKN22100	961 897 003 0	KN22100	N20837J	2
RKN22100	961 897 004 0	KN22100	N20837N	3
RKN22100	961 897 005 0	KN22100	N20837B	1

# FOOT OPERATED VALVES

## Dual Circuit Valves

**MERITOR WABCO**

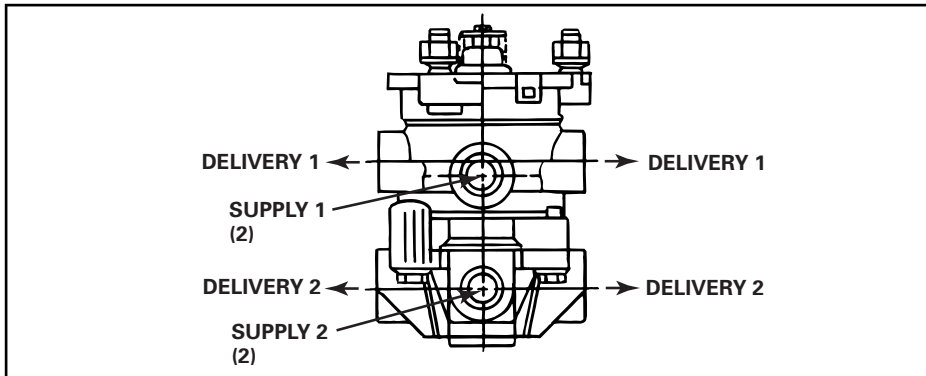
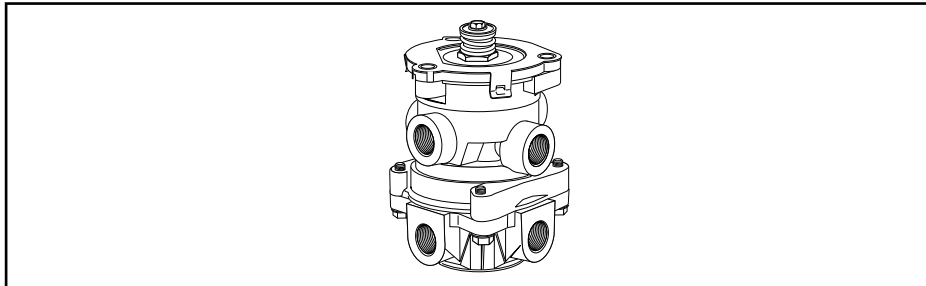

- Provides smooth and consistent pedal feel over competitive application valves.
- A very popular changeover item requires minimal modification.
- Direct replacement for E-6 valve.
- Meets FMVSS-121 requirements.
- All ports are NPTF unless otherwise noted.

### REPLACEMENT PARTS:

For treadle only, see page 49.

Meritor WABCO		Haldex Brake Systems (Midland)		PORTS		MOUNTING STUDS		REMARKS
SERVICE P/N	OEM P/N	SERVICE P/N	OEM P/N	DEL.	SUP.	THD.	LENGTH	
RKN22150	961 899 001 0	KN22150	N30099LA	3/8	3/8	5/16-24	5/8	With studs, nuts, lockwashers
RKN22150	961 899 002 0	KN22150	N30099LB	3/8	3/8	—	—	No studs
RKN22151	961 899 003 0	KN22151	N30099LJ	*	*	—	—	With stoplight switches
RKN22150	961 899 011 0	KN22150	N30099LA	3/8	3/8	5/16-24	5/8	With studs, nuts, lockwashers. Mack application
RKN22150	961 899 015 0	KN22150	N30099LR	3/8	3/8	M8 x 1.25 mm	7/8	With mounting adaptor
RKN22150	961 899 016 0	KN22150	N30099LS	3/8	3/8	5/16-18	1-inch	

PTC = Push-to-Connect fittings

\* = 961 899 003 0 has two delivery and supply port sizes: Delivery 3/8 and 1/2 PTC, Supply 3/8 and 1/2 PTC.



# FOOT OPERATED VALVES

## Single or Dual Circuit Foot Valve and Pedal

**MERITOR WABCO**

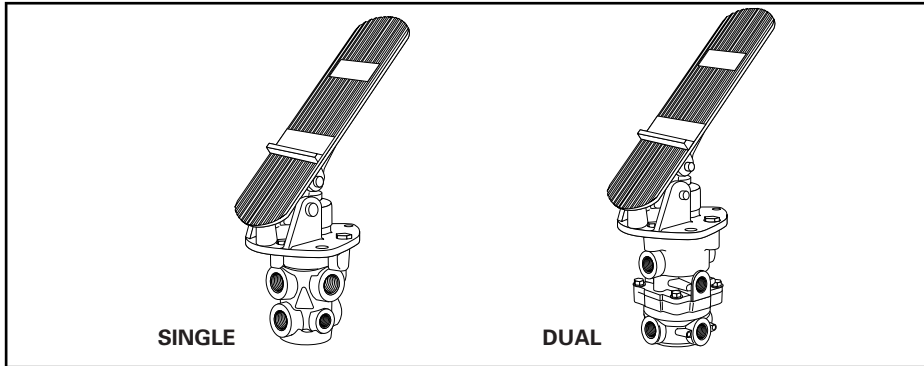

- Features either a single or dual circuit foot valve with pedal attachment.
- An easy way to replace the entire assembly.
- Interchanges with competitive models with a minimum of modifications.
- Weight:  
Single Circuit 3.4 lbs.  
Dual Circuit 4.4 lbs.

### REPLACEMENT PARTS:

For treadle only, see page 49.

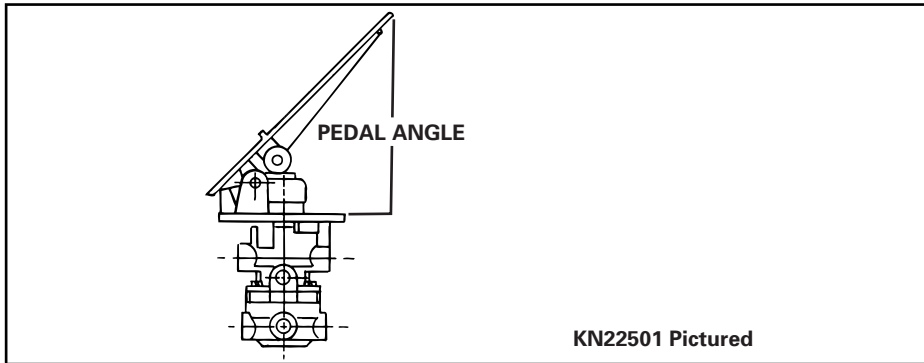

Meritor WABCO		Haldex Brake Systems (Midland)		PEDAL ANGLE	TYPE	REMARKS
SERVICE P/N	OEM P/N	SERVICE P/N	OEM P/N			
RKN22600	961 899 004 0	KN22600	N30072FA	45°	Single	Off-Highway application
RKN22521	961 899 005 0	KN22521	N30072HB	34°	Dual	N30072HC supersedes N30072GC
RKN22501	961 899 006 0	KN22501	N30072HC	45°	Dual	N30072HB supersedes N30072GB
RKN22508	961 899 007 0	KN22508	N30072HD	50°	Dual	
RKN22610	961 899 009 0	KN22610	N30072FC	27°	Single	Off-Highway application

# GLADHANDS

## Hose Couplers (Gladhands) Conventional Style

**MERITOR WABCO**

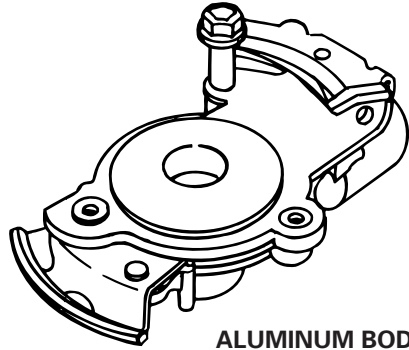

ALUMINUM BODY/STEEL FACE

- Aluminum body/steel face and cast iron units available.
- Heavy duty aluminum body/steel face units.
- Economical — helps lower fleet maintenance cost.
- Universal and polarized configurations available for fleet choice.
- Filtered units help keep air lines free of valve damaging contaminants.
- Polarized units have the letter "S" or "E" die-cast into the body of the gladhand for easy identification of emergency or service.
- Steel face is zinc yellow dichromate and aluminum body is chromate conversion coated for corrosion resistance.
- Interchangeable with competitive gladhands.
- See page 13 for part numbers.

COUPLING, DUMMY AND  
CHAIN ASSEMBLY

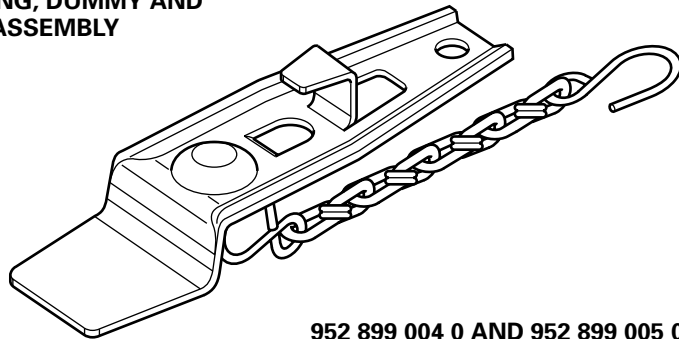

952 899 004 0 AND 952 899 005 0

# GLADHANDS

## Hose Couplers (Gladhands) Conventional Style

**MERITOR WABCO**

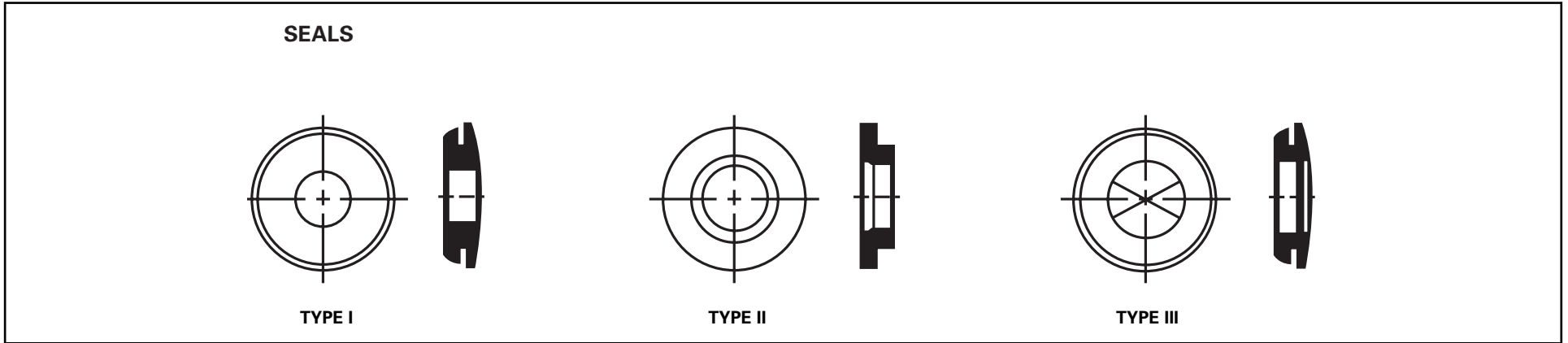

Meritor WABCO		Haldex Brake Systems (Midland)		MATERIAL COMPOSITION	CONFIGURATION	SEAL TYPE	FILTER
SERVICE P/N	OEM P/N	SERVICE P/N	OEM P/N				
R11450	952 899 001 0	11450	N20415MA	Aluminum/Steel	Universal	I	No
R11460	952 899 002 0	11460	N20415MB	Aluminum/Steel	Universal	I	Yes
R11463	952 899 003 0	11463	N20415MC	Aluminum/Steel	Universal	III	Yes
R11402	952 899 004 0	11402	N13048	No Vent	Dummy and Chain Assembly	—	—
R11401	952 899 005 0	11401	N13048A	No Vent	Dummy and Chain Assembly	—	—
R11451	952 899 100 0	11451	N20415NA	Aluminum/Steel	Emergency	I	No
R11451	952 899 101 0	11451	N20415ND	Aluminum/Steel	Emergency	II	No
R11452	952 899 200 0	11452	N20415PA	Aluminum/Steel	Service	I	No
R11452	952 899 201 0	11452	N20415PD	Aluminum/Steel	Service	II	No
R11465	952 899 202 0	11465	N20415NC	Aluminum/Steel	Emergency	III	No
R11464	952 899 203 0	11464	N20415PC	Aluminum/Steel	Service	III	No

# GOVERNORS

## Piston Type Governor

**MERITOR WABCO**

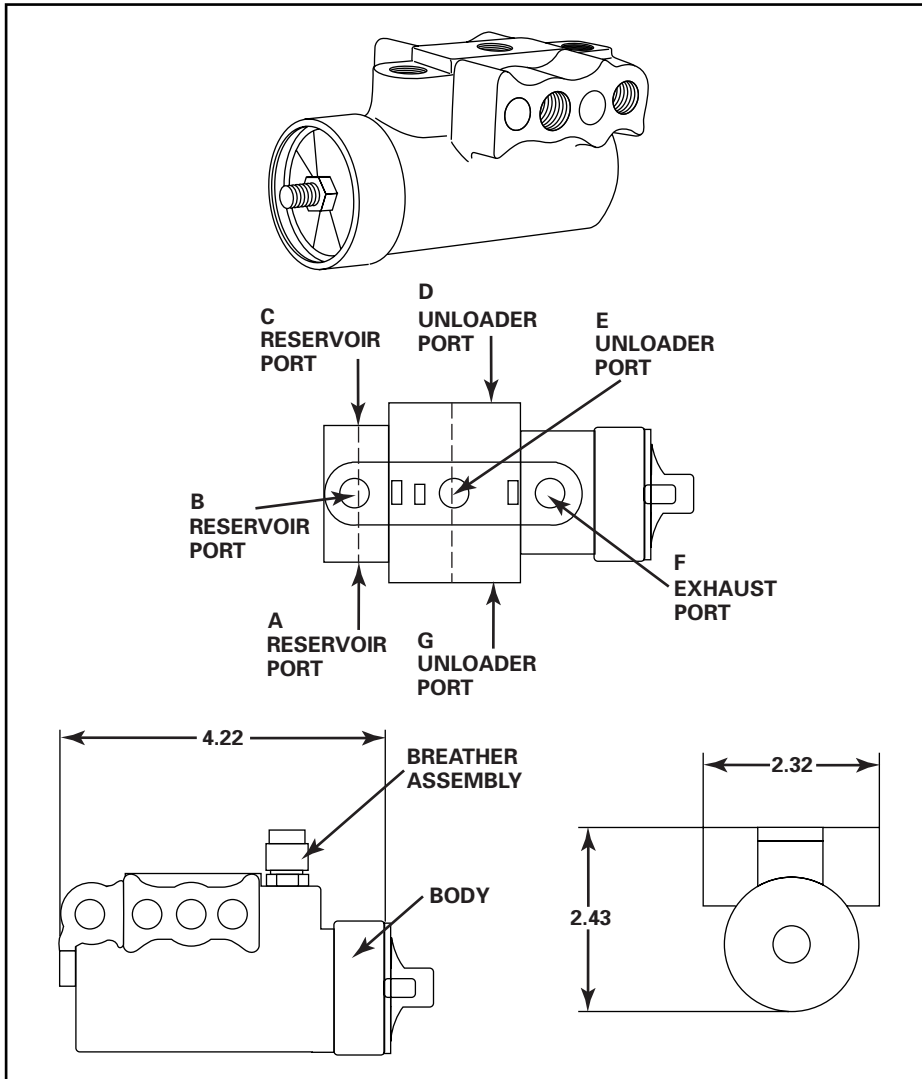

- Operates in conjunction with the compressor unloading mechanism.
- Automatically controls the air pressure in the air supply system between the desired predetermined maximum and minimum pressures.
- Direct compressor or remote governor mounting.
- 0.336 diameter mounting holes.
- Direct replacement for D-2 governor.

**NOTE:** Service units are supplied with dust cover.

**NOTE:** Service units are sent with a factory set cut-in pressure of **105 +5/-0 psi.**

**NOTE:** Service units are sent with all ports open. Plugs are included in the package.

See page 15 for part numbers.

# GOVERNORS

## Piston Type Governor

**MERITOR WABCO**

Meritor WABCO		Haldex Brake Systems (Midland)		PORT THREAD SIZE RES.	PORT THREAD SIZE UNL.	PORT THREAD SIZE EXH.	CUT-IN PRESSURE (+5.0)	PORTS							REMARKS
SERVICE P/N	OEM P/N	SERVICE P/N	OEM P/N					A	B	C	D	E	F	G	
<b>RKN18530</b>	975 499 001 0	<b>†KN18530</b>	<b>†N30190A</b>	1/8-27NPTF	1/8-27NPTF	1/8-27NPTF	95	O	O	O	O	O	O	O	—
RKN18532	975 499 002 0	KN18530	N30190AM	1/8-27NPTF	1/8-27NPTF	1/8-27NPTF	105	O	O	O	O	O	O	O	—
RKN18530	975 499 003 0	KN18530	N30190C	1/8-27NPTF	1/8-27NPTF	1/8-27NPTF	105	P	P	O	P	P	O	O	—
RKN18531	975 499 004 0	KN18531	N30190H	1/4-18NPTF	1/8-27NPTF	1/8-27NPTF	105	P	O	P	P	O	O	P	—
RKN18530	975 499 005 0	KN18530	N30190HA	1/8-27NPTF	1/8-27NPTF	1/8-27NPTF	105	O	O	O	O	O	O	O	Mack Application
RKN18530	975 499 006 0	KN18530	N30190L	1/8-27NPTF	1/8-27NPTF	1/8-27NPTF	105	P	P	O	P	P	O	O	—
RKN18530	975 499 007 0	KN18530	N30190GB	1/8-27NPTF	1/8-27NPTF	1/8-27NPTF	110 ± 10	O	O	O	O	O	B	O	Non-Adjusting
RKN18532	975 499 010 0	<b>†KN18532</b>	<b>†N30190AA</b>	1/8-27NPTF	1/8-27NPTF	1/8-27NPTF	105	O	O	O	O	O	B	O	Water Resistant
RKN18530	975 499 011 0	KN18530	N30190AJ	1/8-27NPTF	1/8-27NPTF	1/8-27NPTF	105	O	P	P	O	P	O	O	—

† Service/OEM part numbers appearing in “**BOLDFACE**” type are exact replacement units.

O = Open

P = Plugged

B = Breather

# HAND OPERATED VALVES

## Trailer Brake Control

**MERITOR WABCO**

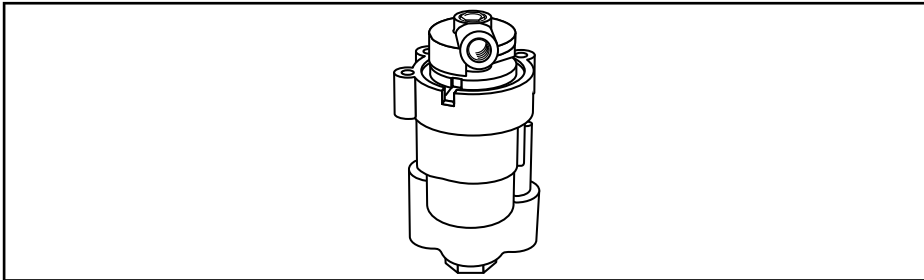

- In-column mount.
- Made of durable EGC (Engineering Grade Composite).
- Handle and knob NOT supplied with service unit.
- All ports are NPTF unless otherwise noted.

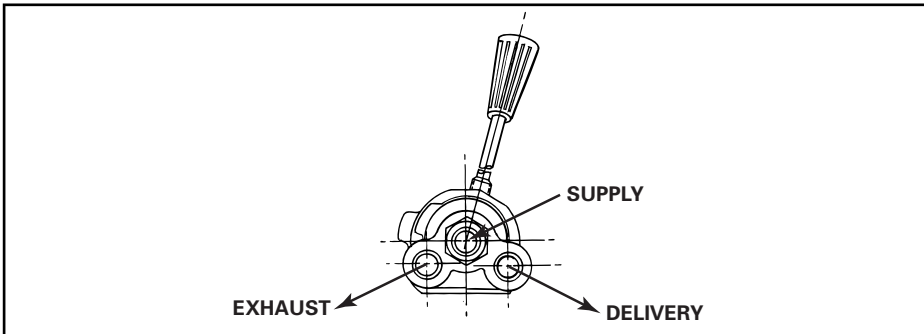

Meritor WABCO		Haldex Brake Systems (Midland)		PORTS	TYPE	TRAVEL	HANDLE
SERVICE P/N	OEM P/N	SERVICE P/N	OEM P/N				
RKN20542	961 799 001 0	KN20542	N30103BL	1/4	Self-Return	70°	No
RKN20542	961 799 003 0	KN20542	N30103BF	1/4	Self-Return	70°	Yes
RKN20542	961 799 004 0	KN20542	N30103BH	1/4	Self-Return	70°	Yes
RKN20541	961 799 005 0	KN20541	N30103BN	1/4	Holding	70°	Yes*
RKN20542	961 799 006 0	KN20542	N30103BY	1/4	Self-Return	70°	Yes
RKN20545	961 799 007 0	KN20545	N30103FC	3/8 PTC / 1/4 PTC exhaust	Self-Return	50°	Yes
RKN20546	961 799 010 0	KN20546	N30103BZ	1/4	Self-Return	70°	Yes*
RN30103FE	961 799 015 0	N30103FE	N30103FE	3/8 PTC / 1/4 PTC exhaust	R.H. Drive	50°	Yes
RKN20542	967 799 015 0	KN20542	N30103BS	1/4	Self-Return	61°	Yes
RKN20541	967 799 016 0	KN20541	N30103BC	1/4	Holding	70°	Yes

PTC = Push-to-Connect fittings

\* Includes mounting brackets

# HAND OPERATED VALVES

## Trailer Brake Control

**MERITOR WABCO**

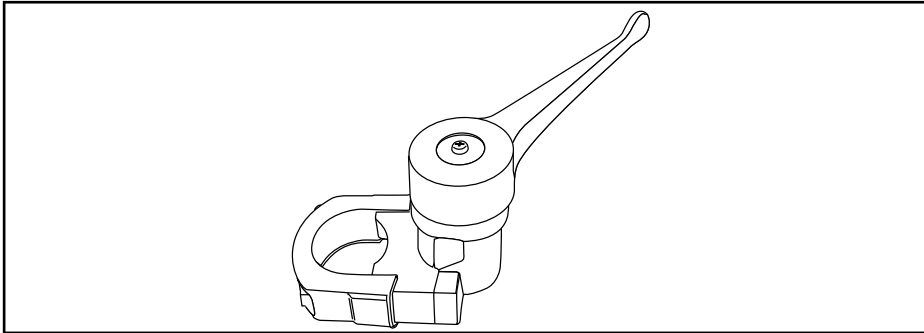

- External steering column mount.
- Handle applies 70° maximum.
- Chrome handle.
- All ports 1/4 NPTF.

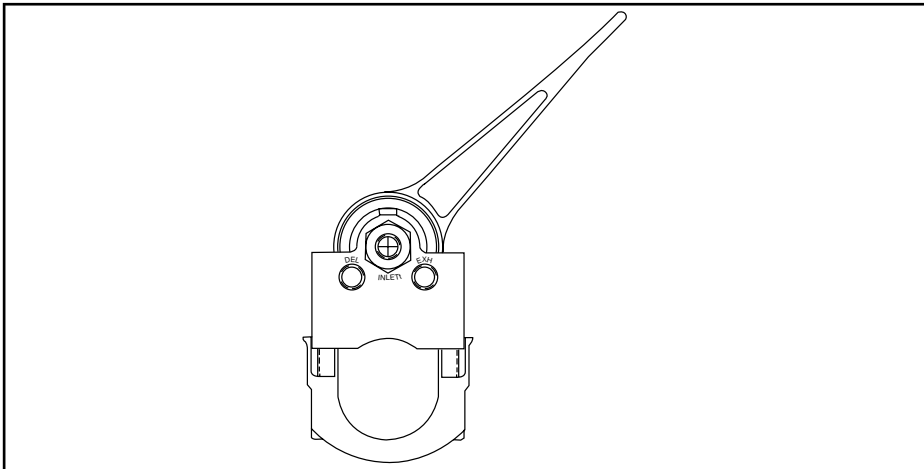

Meritor WABCO		Haldex Brake Systems (Midland)		TYPE	DESCRIPTION
SERVICE P/N	OEM P/N	SERVICE P/N	OEM P/N		
RKN20561	961 799 002 0	KN20561	N30161AH	Holding	With handle, bracket and mounting bolts
RKN20562	—	KN20562	N30161AJ	Self-Ret.	With handle, bracket and mounting bolts

# HAND OPERATED VALVES

## Trailer Brake Control

**MERITOR WABCO**

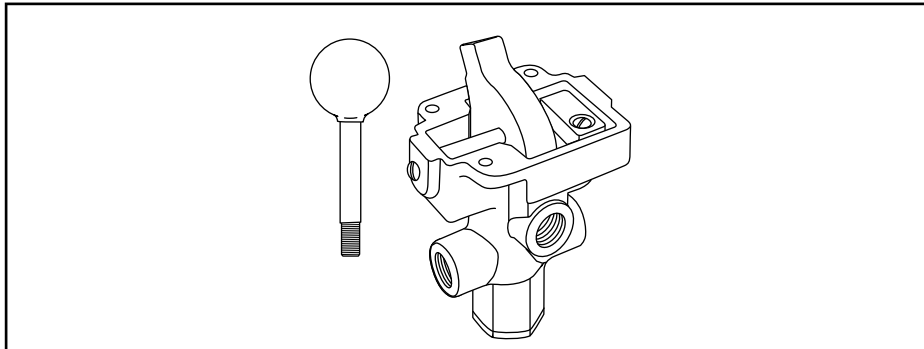

- Panel mount.
- All ports 1/4 NPTF.
- Contact original equipment manufacturer for knob replacement not covered below.
- 58° travel.

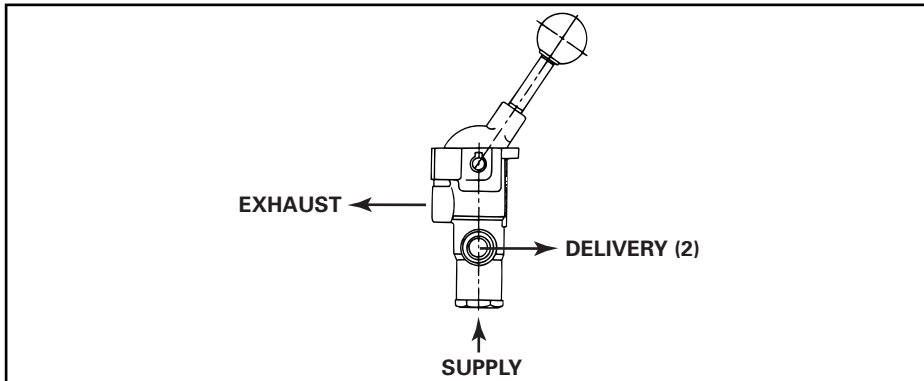

Meritor WABCO		Haldex Brake Systems (Midland)		MAXIMUM DELIVERY	TYPE	DESCRIPTION
SERVICE P/N	OEM P/N	SERVICE P/N	OEM P/N			
RKN20580	961 799 011 0	KN20580	N30105B	80 psi	Self-Returning	With 2-inch lever and knob
RKN20590	961 799 012 0	KN20590	N30105C	50 psi	Self-Returning	With 2-inch lever and knob
RKN20581	961 799 013 0	KN20581	N30105D	Sys. Pres.	Holding	With 5-inch lever, no knob
RN30105H	961 799 014 0	KN20585	N30105H	65-75 psi	Self-Returning	With 5-inch lever, no knob



# HAND OPERATED VALVES

## Single Flipper Style Valves

**MERITOR WABCO**

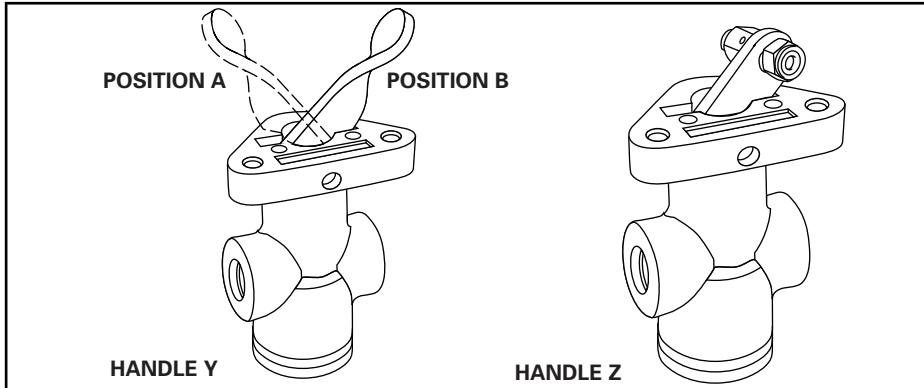

- Panel mount.
- Made of durable EGC (Engineering Grade Composite).
- An on-off, non-automatic two position valve.
- All ports 1/8 NPTF.
- All mounting holes are #10-24 except where noted.
- Mounting holes 1.50-inch centers, except where noted.
- Weight 0.18 lb.
- Handle: **STYLE Y:** Chrome or black finish  
**STYLE Z:** Bowden wire, 5 swivel, reversible with machine screw

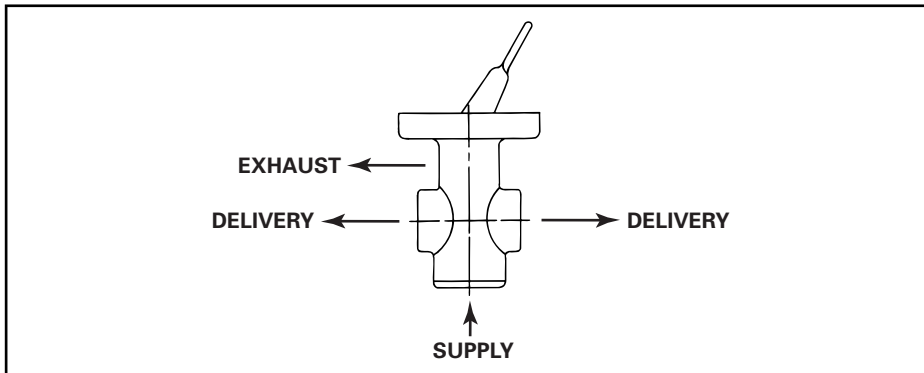

Meritor WABCO		Haldex Brake Systems (Midland)		RELEASE POSITION	TYPE	HANDLE FINISH	REMARKS
SERVICE P/N	OEM P/N	SERVICE P/N	OEM P/N				
RKN20001	934 190 002 0	KN20001	N13440DA	A	Y	Chrome	
RKN20001	934 190 003 0	KN20001	N13440DB	A	Y	Chrome	Mounting holes: (1) #10-24, (1) .22 dia.
RKN20001	934 190 004 0	KN20001	N13440DC	B	Y	Black	Mounting holes: (1) #10-24, (1) .22 dia.
RKN20041	934 190 005 0	KN20041	N13440DD	A	Z	—	Mounting holes: (1) #10-24, (1) .22 dia.
RKN20041	934 190 006 0	KN20001	N13440DJ	A	Z	Chrome (with face plate)	
RKN20001	934 190 007 0	KN20001	N13440DL	A	Y	Chrome	
RKN20001	934 190 013 0	KN20001	RVN13440DL	A	Y	Chrome	

# HAND OPERATED VALVES

## Double Flipper Style Valves

**MERITOR WABCO**

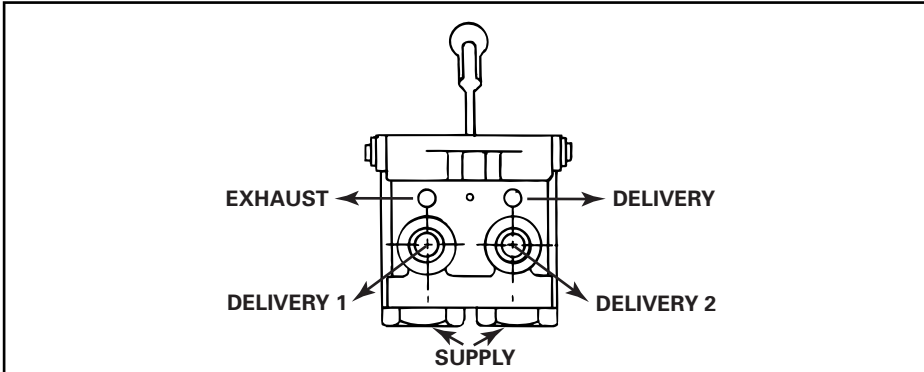
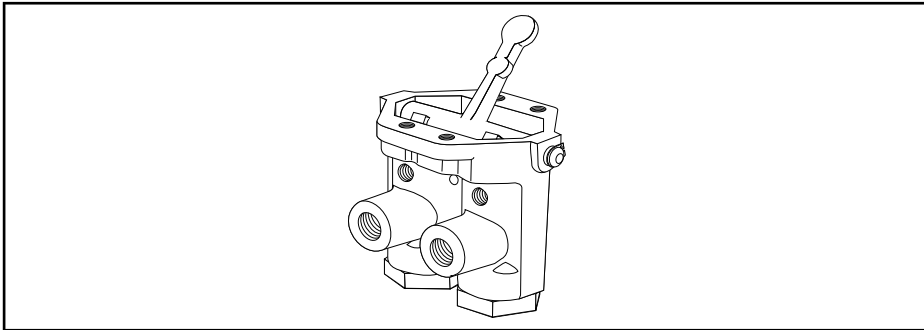

- Panel mount.
- Directional air control valve.
- May be used for control of push-pull air cylinders or various other air operated devices.
- All units supplied with handle.
- Four mounting holes — #10-24.
- All ports are NPTF.
- Applied/Hold Positions (See Chart Below):
  1. 3 Position with MANUAL RELEASE ONLY.
  2. 3 Position with AUTOMATIC RELEASE when Delivery 2 is APPLIED.
  3. 2 Position with MANUAL RELEASE ONLY.

Meritor WABCO		Haldex Brake Systems (Midland)		APPLIED/HOLD POSITIONS	PORT SIZES		
SERVICE P/N	OEM P/N	SERVICE P/N	OEM P/N		SUPPLY		DELIVERY 2 PLACES
					A	B	
RKN20080	934 190 008 0	KN20080	N15791D	1	1/4	1/4	1/8
RKN20090	934 190 009 0	KN20090	N15791F	2	1/4	1/4	1/8
RN15791H*	934 190 010 0	N15791H	N15791H	2	Plug	1/4	1/8
RN15791T	934 190 011 0	N15791T	N15791T	3	1/8	1/8	1/8
RN15791V*	934 190 012 0	N15791V	N15791V	2	Plug	1/4	1/8

\* With face plate

# HAND OPERATED VALVES

## Park Brake Valves, 2-Knob

**MERITOR WABCO**

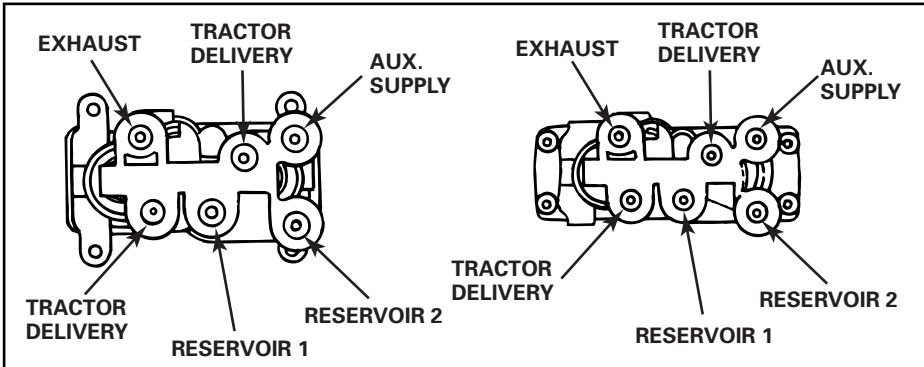
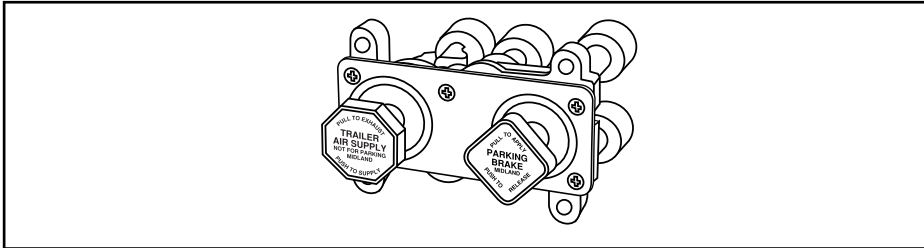

- One piece body construction.
- Smaller valve size offers more room behind the dash for hoses and accessibility. Made of durable EGC (Engineering Grade Composite). All ports have molded in identification.
- Direct replacement for the MV2 or MV3 valves.
- All ports are NPTF unless otherwise noted.
- Weight 1.5 lbs.
- Includes red and yellow knobs.
- All have the following PSI performance spec:  
**TRAILER VALVE** — 40 ± 5  
**PARKING VALVE** — 30 ± 5  
**NON-OVERRIDE FUNCTION** — 25 ± 5

**REPAIR KIT: RRN31BF (Haldex RN31BF)**

Meritor WABCO		Haldex Brake Systems (Midland)		4-MOUNTING HOLES THREADED INSERTS	MOUNTING/ KNOB ORIENTATION	PORTS	REMARKS
SERVICE P/N	OEM P/N	SERVICE P/N	OEM P/N				
RKN20615	934 649 021 0	KN20615	N4400	.28 dia.	Horizontal	1/4	—
RKN20606	934 649 022 0	KN20606	N4400M	1/4-20 UNC-2B	Horizontal	1/4	Volvo/GM cover part; standard mounting pattern
RKN20607	936 640 012 0	KN20607	N4400S	M6 x 1-6H	Vertical	3/8 PTC	Volvo Application
RKN20603	936 649 003 0	KN20603	N4400G	M6 x 1-6H	Horizontal	1/4	Metric mounting threads
RKN20612	936 649 004 0	KN20612	N4400A	10-24 UNC-2B	Horizontal	1/4	—
RKN20611	936 649 005 0	KN20611	N4400B	1/4-20 UNC-2B	Horizontal	1/4	—
RKN20608	936 649 011 0	KN20608	N4400R	1/4-20 UNC28	Horizontal	3/8 PTC	Volvo (1/4 NPTF Exhaust)
RKN20622	936 649 018 0	KN20622	N4400BC	5/16 dia.	Vertical	3/8 PTC	Freightliner Application
RKN20619	936 649 026 0	KN20619	N4400BA	.24 dia.	Horizontal	3/8 PTC	Volvo Application

PTC = Push-to-Connect

# HAND OPERATED VALVES

## Park Brake Valves, 1-Knob

**MERITOR WABCO**

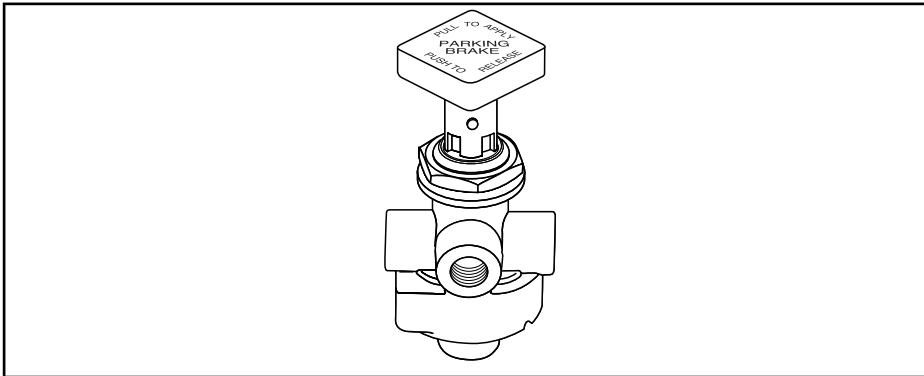

- Controls parking/emergency brakes.
- Bulkhead mount — 7/8-inch. 7/8-inch mounting hole required.
- Made of durable EGC (Engineering Grade Composite).
- Won't rust or corrode.
- Direct replacement for the PP-1 valve.
- All ports 1/8-27 NPTF.

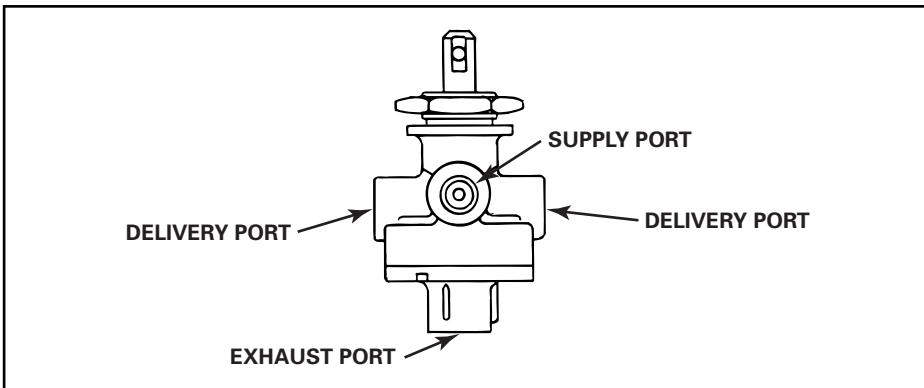

Meritor WABCO		Haldex Brake Systems (Midland)		POP PRESSURE	REMARKS
SERVICE P/N	OEM P/N	SERVICE P/N	OEM P/N		
RKN20021	936 649 001 0	KN20021	N20960	35 ± 10 psi	
RKN20021	936 649 009 0	KN20021	N20960	35 ± 10 psi	
RN20960A	936 649 014 0	N20960A	N20960A	35 ± 10 psi	Truck only
RKN20624	936 649 102 0	KN20624	N4400DC	30 ± 5 psi	

# HAND OPERATED VALVES

## Push-Pull Style Valves

**MERITOR WABCO**

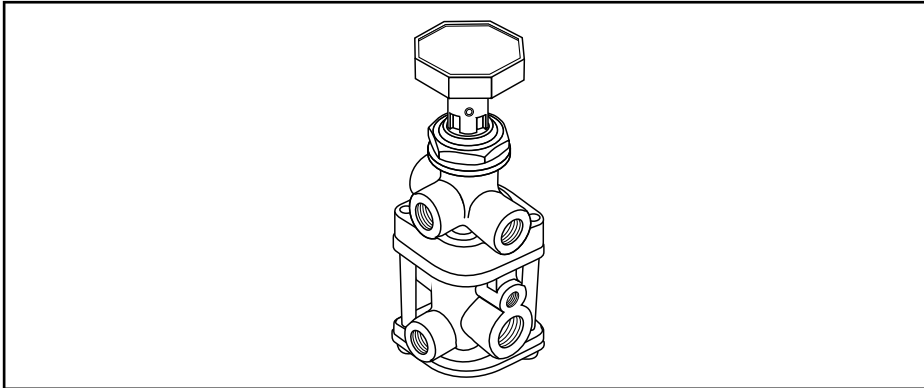

### TRAILER AIR SUPPLY VALVE

- Controls tractor protection valve and trailer parking brakes.
- Bulkhead mount — 7/8-inch.
- Made of durable EGC (Engineering Grade Composite).
- Won't rust or corrode.
- Direct replacement for the PP-7.
- Exhaust and delivery 1/4-18 NPTF.
- Supply and control 1/8-27 NPTF.

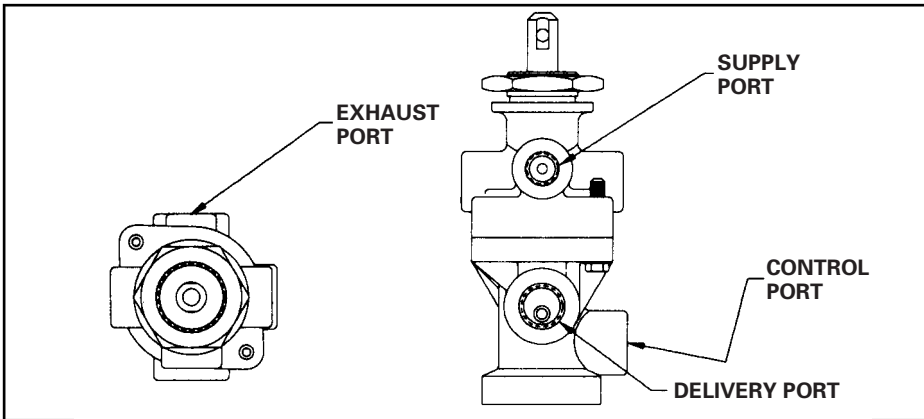

Meritor WABCO		Haldex Brake Systems (Midland)		POP PRESSURE	NON-OVERRIDE PRESSURE	REMARKS
SERVICE P/N	OEM P/N	SERVICE P/N	OEM P/N			
RKN20025	936 649 002 0	KN20025	N20961	35 psi	25 psi	With knob, 7/8" mounting hole required

# HAND OPERATED VALVES

## Push-Pull Style Valves

**MERITOR WABCO**

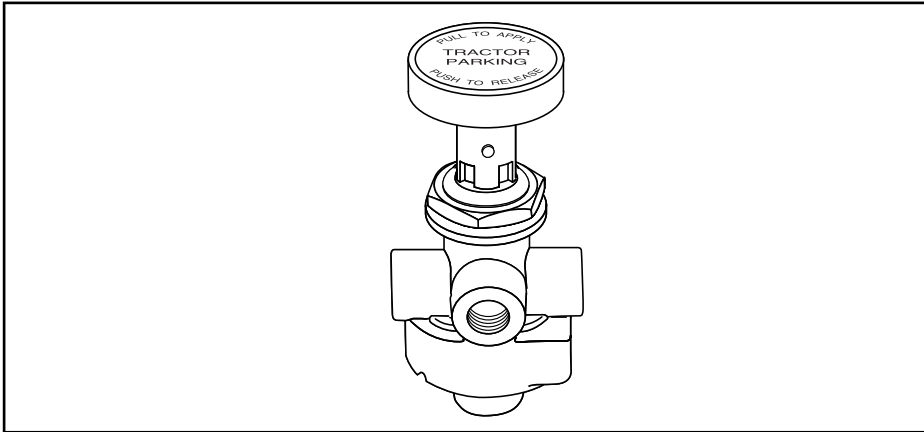

- Controls TRACTOR ONLY parking.
- Bulkhead mount — 7/8-inch.
- Made of durable EGC (Engineering Grade Composite).
- Direct replacement for the PP-8.
- Will not stay in half-on – half-off position.
- Won't rust or corrode.
- All ports 1/8-27 NPTF.

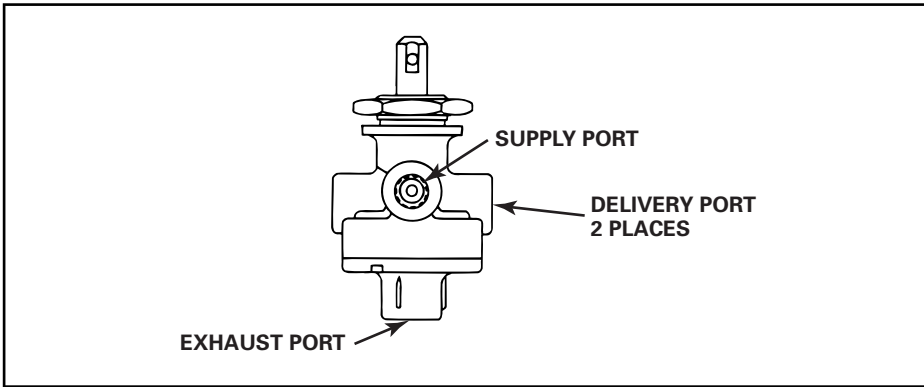

Meritor WABCO		Haldex Brake Systems (Midland)		POP PRESSURE	REMARKS
SERVICE P/N	OEM P/N	SERVICE P/N	OEM P/N		
RKN20035	936 649 015 0	KN20035	N20964	17.5 ± 12.5 psi	With knob, 7/8" mounting hole required

# HAND OPERATED VALVES

## Push-Pull Style Valves

**MERITOR WABCO**

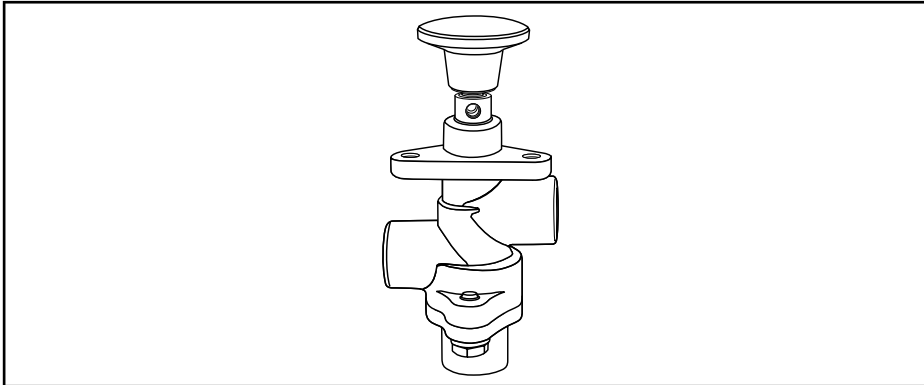

- Known as "Hostler Valve."
- Panel or bulkhead mount.
- Requires 3/4-inch mounting hole.
- 1/4 delivery and exhaust ports.

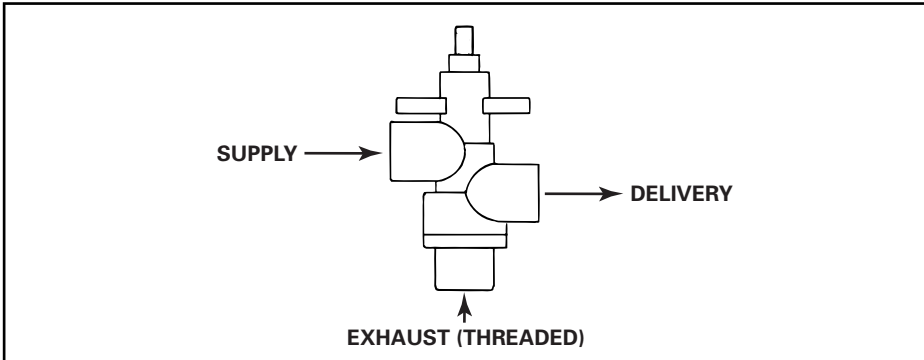

Meritor WABCO		Haldex Brake Systems (Midland)		POP PRESSURE	REMARKS
SERVICE P/N	OEM P/N	SERVICE P/N	OEM P/N		
RKN20010	934 649 016 0	KN20010	N14488	25/40 psi	With N14515 knob
RN14488R	934 649 017 0	N14488R	N14488R	0 psi	Knob, plate and mounting screws are shipped loose
RKN20020	934 899 013 0	KN20020	N14488AK	25/40 psi	No knob (no face plate)

# INVERSION VALVES

**MERITOR WABCO**

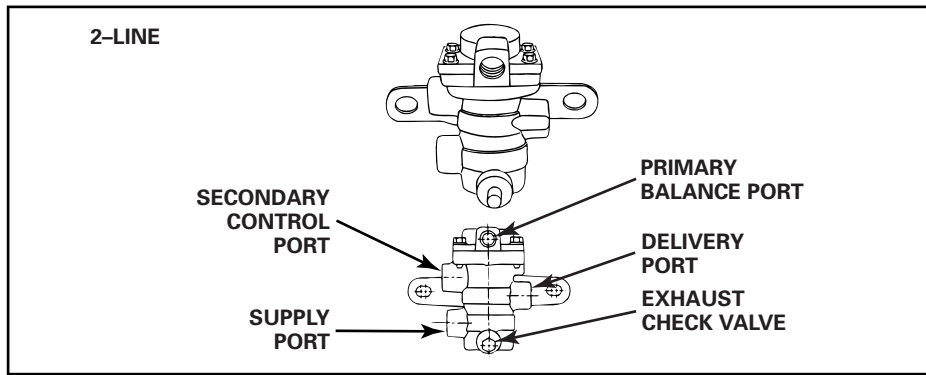

## INVERSION VALVE (2-LINE)

- All ports NPTF unless otherwise noted.
- Used prior to March 1, 1998 on any truck or bus brake system.
- Used after March 1, 1998 on truck or bus brake systems that have two control lines to a rear service relay valve that has a double check built in.
- Direct replacement for SR-1 valve.

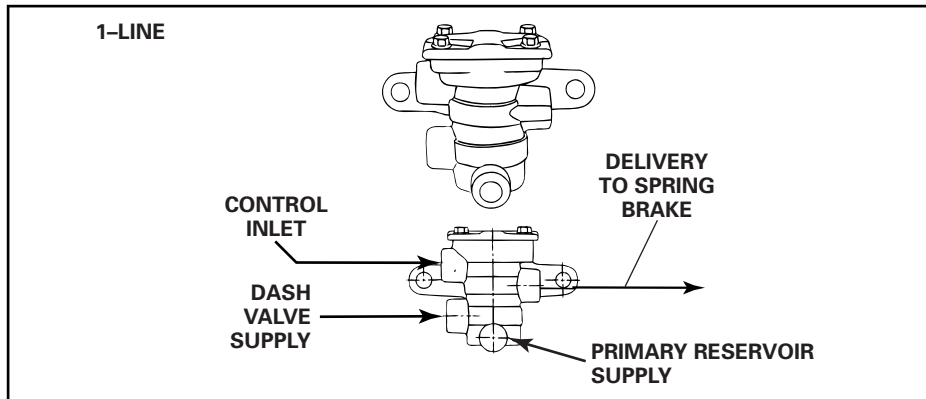

## NEW INVERSION VALVE (1-LINE)

- Used after March 1, 1998 on truck or bus brake systems that have one control line to the rear service relay valve.

Meritor WABCO		Haldex Brake Systems (Midland)		LINES REQUIRED		PORTS	REMARKS
SERVICE P/N	OEM P/N	SERVICE P/N	OEM P/N	SECONDARY CONTROL	PRIMARY BALANCE		
RKN28030	971 899 001 0	KN28030	N20950AA	Yes	No	1/4	
RKN28032	971 899 002 0	KN28032	N20950CA	Yes	Yes	1/4	
RKN28030	971 899 004 0	KN28030	N20950AA	Yes	No	1/4	
RKN28030	971 899 005 0	KN28030	N20950AA	Yes	No	1/4	Mack Application
RKN28033	971 899 007 0	KN28033	N20950CD	Yes	Yes	1/4 PTC	
RKN28034	971 899 008 0	KN28034	N20950AB	Yes	No	1/4 PTC	

PTC = Push-to-Connect fittings



# PRESSURE RELIEF VALVES

**MERITOR WABCO**

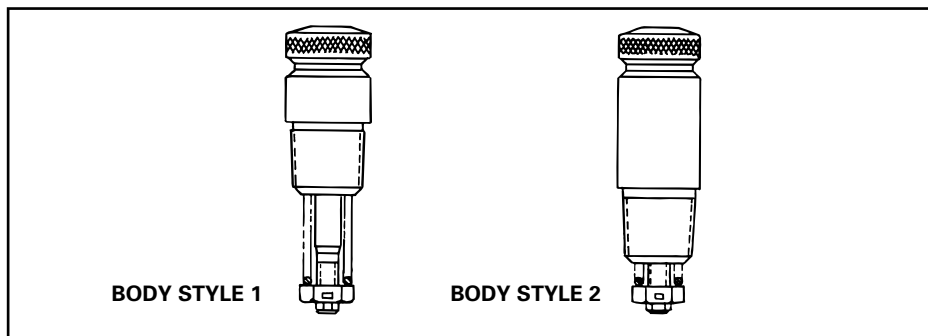

- Made of brass and stainless steel.
- Won't rust or corrode.

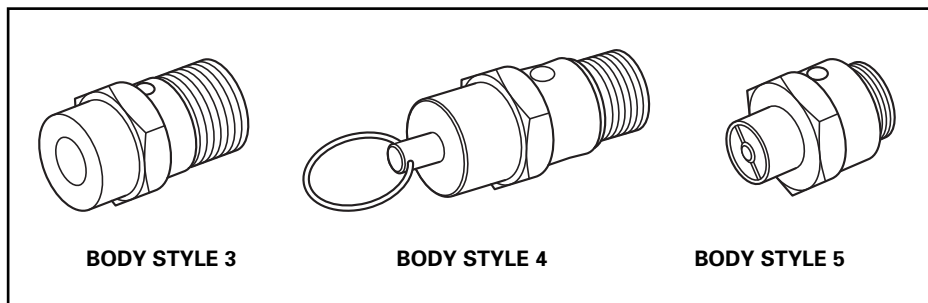

Meritor WABCO		Haldex Brake Systems (Midland)		PIPE THREAD SIZE	BODY STYLE	PSI (Factory Set)
SERVICE P/N	OEM P/N	SERVICE P/N	OEM P/N			
RKN31300	963 880 001 0	KN31250	N1178AB	3/8	1	150
RKN31300	963 880 003 0	KN31300	N1178AC	1/2	1	150
RKN31200	963 880 004 0	KN31200	N1178BA	1/4 sealant	1	150
RKN31250	963 880 005 0	KN31250	N1178BB	3/8 sealant	1	150
RKN31250	963 880 006 0	KN31250	N1178BB	3/8 sealant	1	150
RKN31200	963 880 007 0	KN31200	N1178BA	1/4 sealant	1	150
RKN31200	963 880 008 0	KN31200	N1178AA	1/4	1	150
RKN31400	963 880 010 0	KN31400	N1178CA	1/4	2	150
S963 880 011 0	963 880 011 0	—	—	1/4	4	Compressor Application, 400°F
S963 880 012 0	963 880 012 0	—	—	16 mm	5	150
RKN31528	963 880 020 0	KN31528	N1178EC	1/4 sealant	3	170

# QUICK RELEASE VALVES

**MERITOR WABCO**

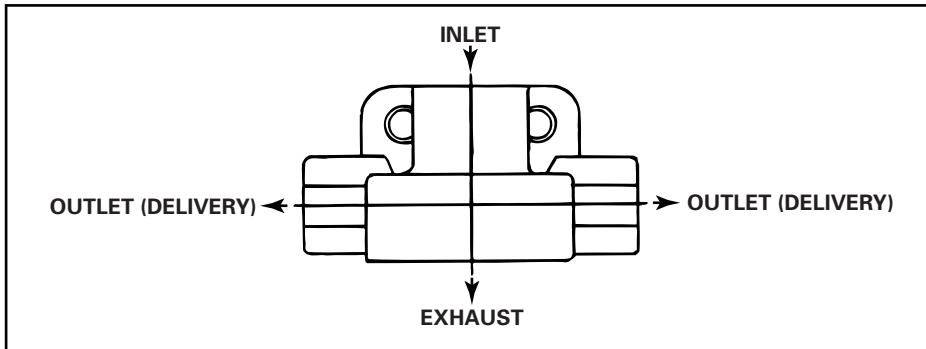
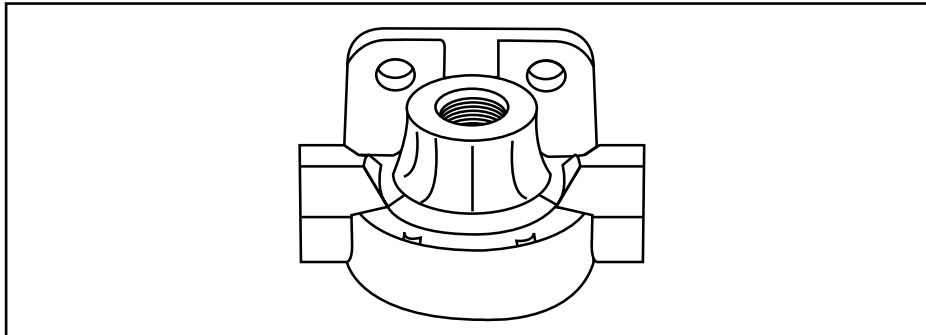

- Used wherever a quick release function is required in the air brake system.
- Made of durable EGC (Engineering Grade Composite).
- Corrosion and weather resistant.
- Utilizes an oil resistant diaphragm for longer life.
- Aids in meeting FMVSS-121 timing requirements.
- Direct replacement for competitive models, including QR-1, QRN and QRN-2.
- All ports are NPTF unless otherwise noted.

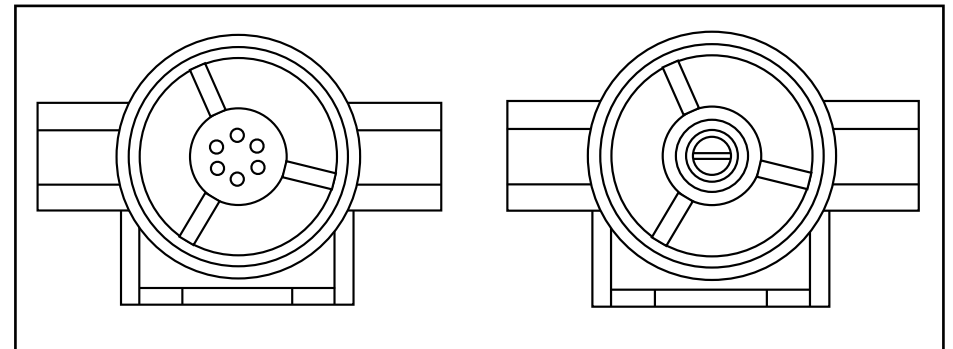

Meritor WABCO		Haldex Brake Systems (Midland)		INLET PORT	OUTLET DELIVERY PORTS	DIFFERENTIAL PSI
SERVICE P/N	OEM P/N	SERVICE P/N	OEM P/N			
RKN32060	973 899 001 0	KN32060	N20959DB	3/8	3/8	6
RKN32011	973 899 002 0	KN32011	N20959EA	1/2	3/8	0
RKN32005	973 899 003 0	KN32005	N20959EB	3/8	3/8	0
RKN32006	973 899 004 0	KN32006	N20959HB	3/8	3/8	3
RKN32003	973 899 007 0	KN32003	N20959HA	1/2	3/8	3
RKN32050	973 899 008 0	KN32050	N20959DA	1/2	3/8	6
RKN32071	973 899 010 0	KN32071	N20959LA	1/2 PTC	3/8 PTC	0
RKN32011	973 899 011 0	KN32011	N20959MA	1/2	3/8	0

# QUICK RELEASE VALVES

**MERITOR WABCO**

(continued)

Meritor WABCO		Haldex Brake Systems (Midland)		INLET PORT	OUTLET DELIVERY PORTS	DIFFERENTIAL PSI
SERVICE P/N	OEM P/N	SERVICE P/N	OEM P/N			
RKN32003	973 899 012 0	KN32003	N20959HC	3/8	3/8	3
RKN32008	973 899 013 0	KN32008	N20959ME	1/2 PTC	1/2 PTC	0
RKN32014	973 899 019 0	KN32014	N20959MF	1/2	1/2 PTC	0
RKN32061	973 899 020 0	KN32061	N20959NE	1/2 PTC, 90°	1/2 PTC	3
RKN32062	973 899 021 0	KN32062	N20959NF	1/2 PTC, 90°	1/2 PTC	6
RKN32015	973 899 022 0	KN32015	N20959MH	1/2 PTC, 90°	1/2 PTC	0

PTC = Push-to-Connect fittings

90° = Elbow

# QUICK RELEASE VALVES

## Quick Release Valve with Two-Way Check

**MERITOR WABCO**

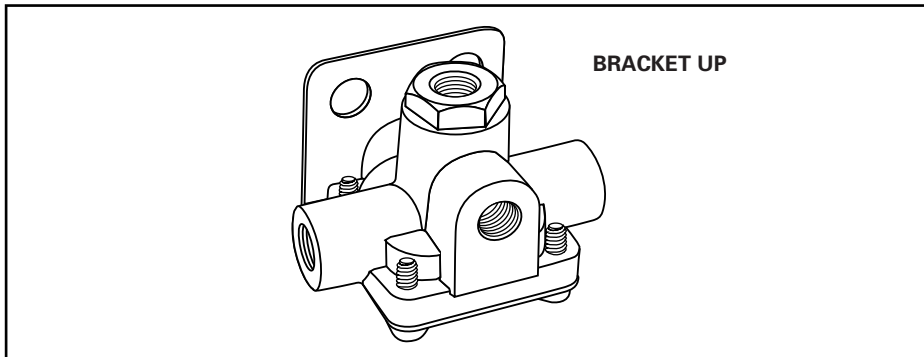

- Used in spring brake control circuits to prevent compounding on trucks and tractors.
- Contains a quick release valve with a built-in two-way check valve.
- Replaces two valves with one.
- The diaphragm and disc are oil resistant for longer life.
- 1.50-inch mounting centers.
- Direct replacement for QR-1C valve.
- All ports are NPTF unless otherwise noted.

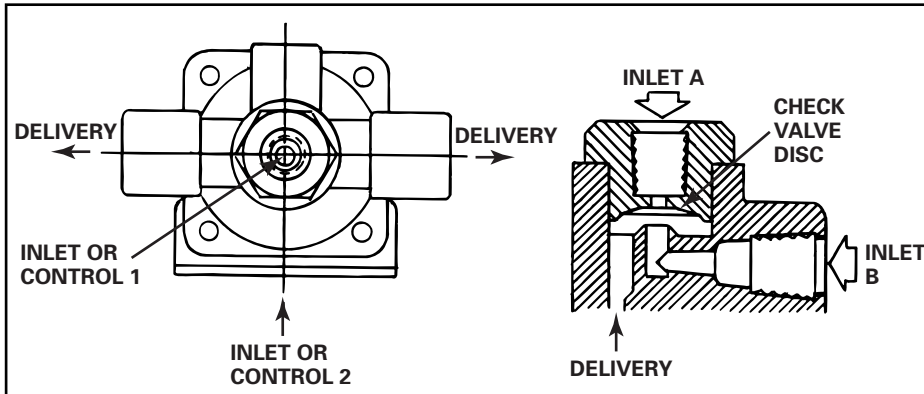

Meritor WABCO		Haldex Brake Systems (Midland)		INLET OR CONTROL		DELIVERY		BRACKET POSITION
SERVICE P/N	OEM P/N	SERVICE P/N	OEM P/N	1 — FROM PARK CONTROL VALVE	2 — FROM REAR AXLE SERVICE BRAKE			
RKN32041	934 099 010 0	KN32041	N20952AD	1/4	1/4	3/8	3/8	Up
RKN32041	934 099 015 0	KN32041	N20952AF	1/4	1/4	3/8	3/8	Up (Volvo)
RKN32041	934 099 020 0	KN32041	N20952AE	1/4	1/4	3/8	3/8	Down
RKN32040	934 099 024 0	KN32040	N20952AB	1/4	1/4	1/4	1/4	Up
RKN32043	934 099 026 0	KN32043	N20952BA	3/8 PTC	3/8 PTC	3/8	3/8	Up

PTC = Push-to-Connect fittings

# QUICK RELEASE VALVES

## In-Line

**MERITOR WABCO**

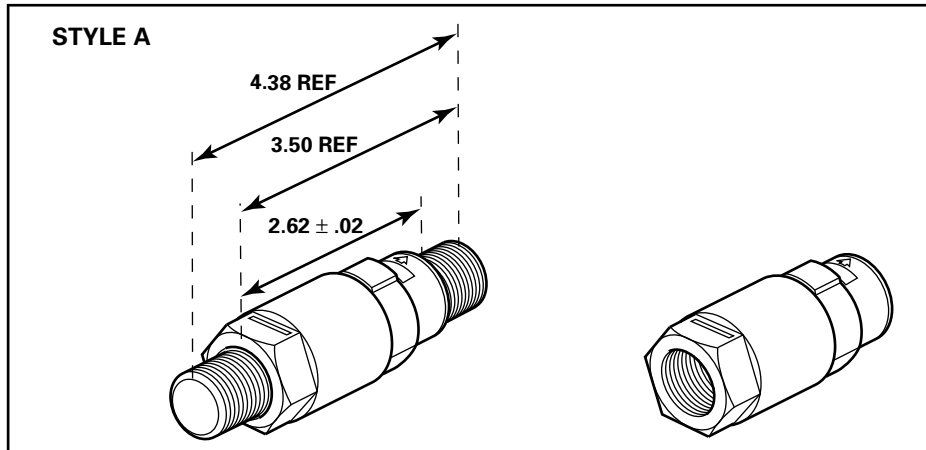

- Valve designed for mounting in-line at the tractor protection valve or at the tractor's gladhand, in either the service or supply line, on heavy truck air brake systems.
- Style A available with or without fittings.
- See page 32 for part numbers.

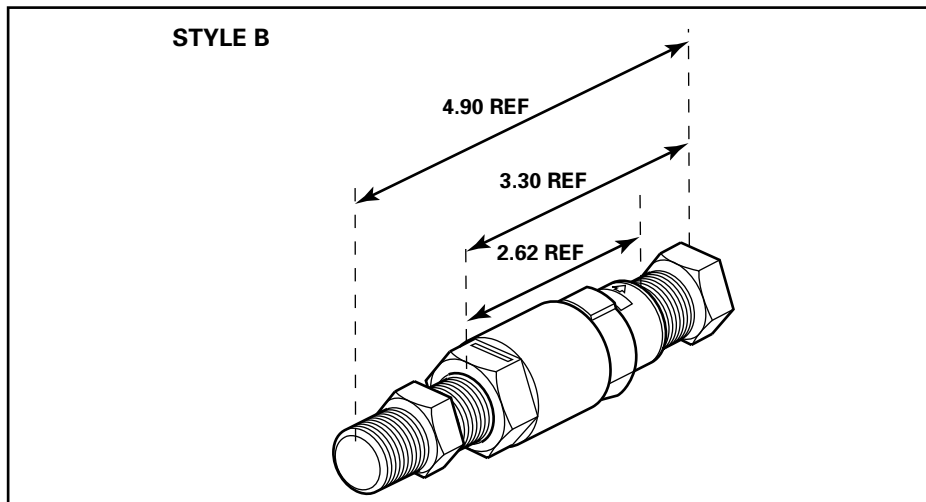

# QUICK RELEASE VALVES

## In-Line

**MERITOR WABCO**

Meritor WABCO		NIPPLE TRACTOR SIDE	VIBRA-SEAL TRACTOR SIDE	NIPPLE OR BUSHING TRAILER SIDE	VIBRA-SEAL TRAILER SIDE	PROTECTIVE SCREEN	VALVE STYLE
SERVICE P/N	OEM P/N						
S973 899 023 0	973 899 023 0	No	No	Yes	No	Yes	A
S973 899 024 0	973 899 024 0	No	No	Yes	No	Yes	A
S973 899 025 0	973 899 025 0	Yes	Yes	No	No	Yes	A
S973 899 026 0	973 899 026 0	Yes	Yes	No	No	Yes	A
S973 899 027 0	973 899 027 0	Yes	Yes	No	No	Yes	A
S973 899 028 0	973 899 028 0	Yes	Yes	No	No	Yes	A
S973 899 029 0	973 899 029 0	No	No	Yes	No	Yes	A
S973 899 030 0	973 899 030 0	No	No	Yes	Yes	Yes	A
S973 899 031 0	973 899 031 0	No	No	Yes	Yes	Yes	A
S973 899 032 0	973 899 032 0	Yes	Yes	No	No	Yes	A
S973 899 033 0	973 899 033 0	Yes	Yes	No	No	Yes	A
S973 899 034 0	973 899 034 0	No	No	Yes	Yes	Yes	A
S973 899 035 0	973 899 035 0	No	No	Yes	No	No	A
S973 899 036 0	973 899 036 0	No	No	No	No	Yes	A
S973 899 037 0	973 899 037 0	No	No	No	No	Yes	A
S973 899 038 0	973 899 038 0	Yes	Yes	Yes	No	Yes	B

# REGULATING VALVES

## Air Regulating Valves

**MERITOR WABCO**

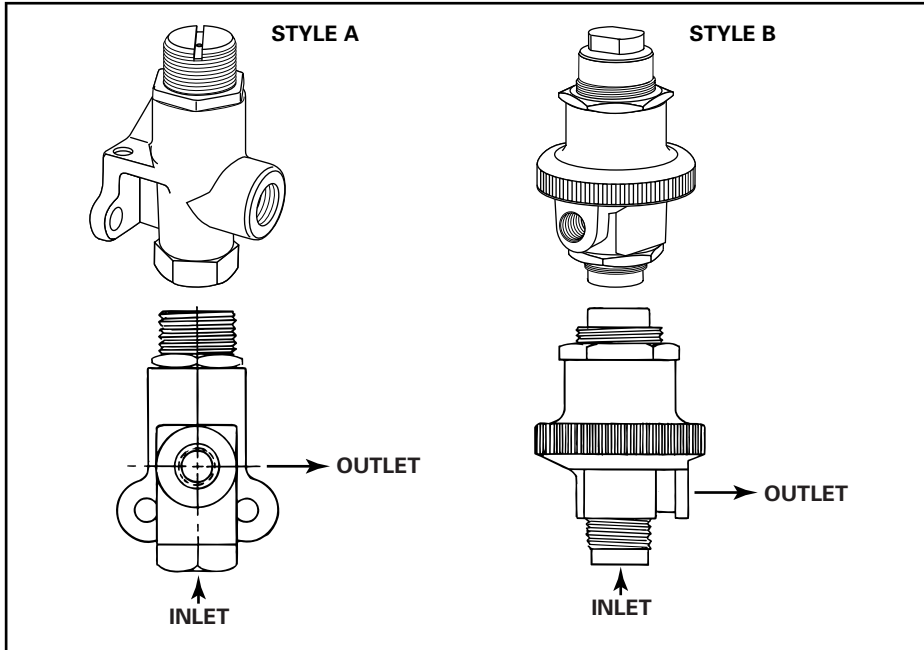

### ADJUSTABLE

- For auxiliary systems only. Not used in the brake system.
- Used in air systems where reduced levels are required.
- Pressure settings are based on 100 psi supply. Factory pre-set as charted.
- Designed for constant supply, not on-off applications.
- A popular use is with air cylinders on bus door operators.

Meritor WABCO		Haldex Brake Systems (Midland)		FACTORY PRESSURE SETTING ( $\pm$ 5 PSI)	INLET	OUTLET	STYLE
SERVICE P/N	OEM P/N	SERVICE P/N	OEM P/N				
RN15817A	934 499 001 0	RN15817A	N15817A	20 psi	1/4	1/4	A
RKN31050	934 499 002 0	KN31050	N15817E	40 psi	1/4	1/4	A
RKN31050	934 499 003 0	KN31050	N15817F	45 psi	1/4	1/4	A
RKN31060	934 499 004 0	KN31060	N15817M	75 psi	1/4	1/4	A
RKN31060	934 499 005 0	KN31060	N15817K	65 psi	1/4	1/4	A
RN13680BC	934 499 006 0	N13680BC	N13680BC	35 psi	3/8	1/4	B
RKN31082	934 499 007 0	KN31082	N13680BK	85 psi	3/8	1/4	B
RKN31080	934 499 008 0	KN31080	N13680BL	60 psi	3/8	1/4	B
RN13680BZ	934 499 009 0	N13680BZ	N13680BZ	50 psi	3/8	1/4	B
RKN31050	934 499 010 0	KN31050	N15817G	50 psi	1/4	1/4	A
RKN31081	934 499 012 0	KN31081	N13680BD	100 psi	3/8	1/4	B

# RELAY VALVES

## Bracket Styles

**MERITOR WABCO**

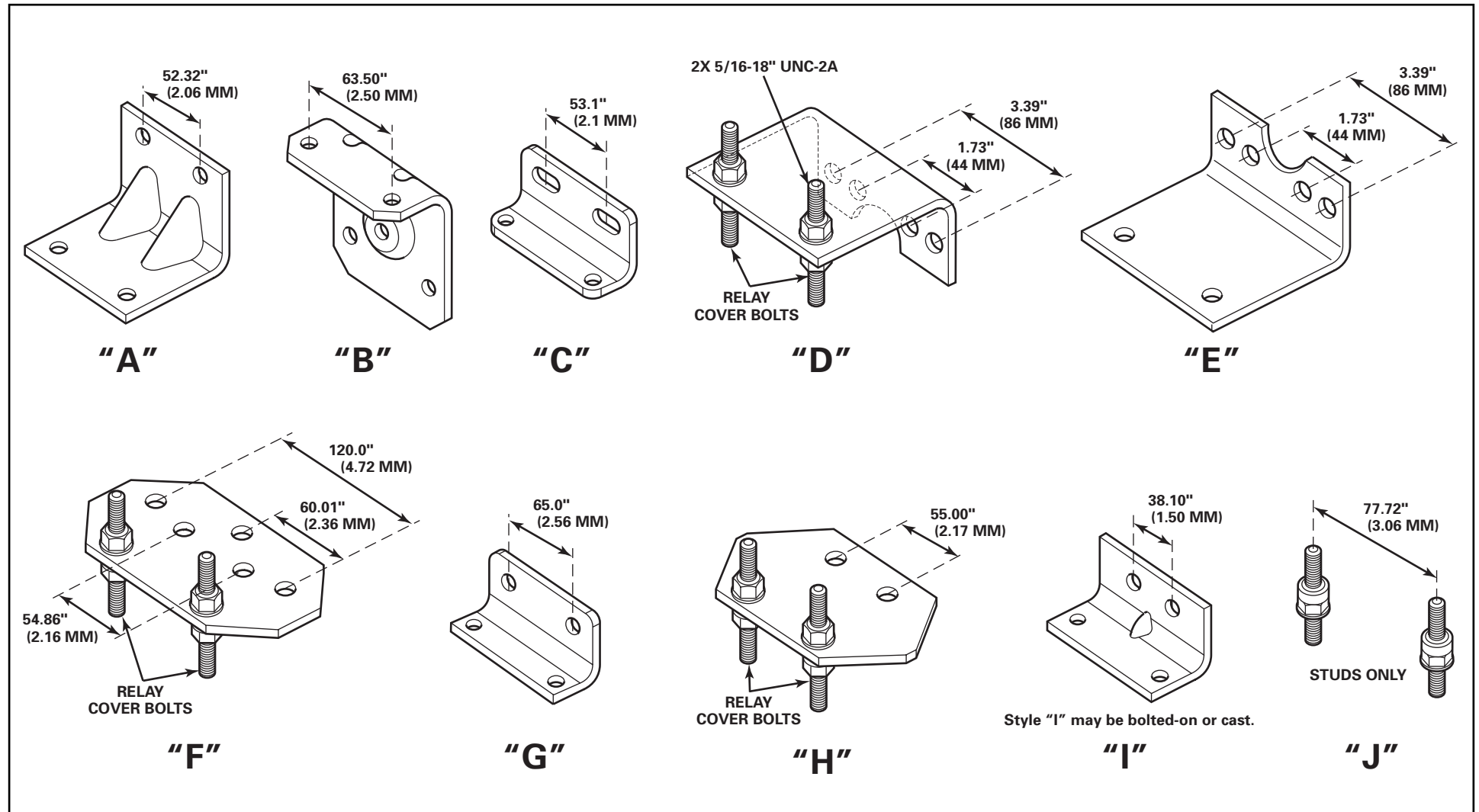



# RELAY VALVES

## RG-2

**MERITOR WABCO**

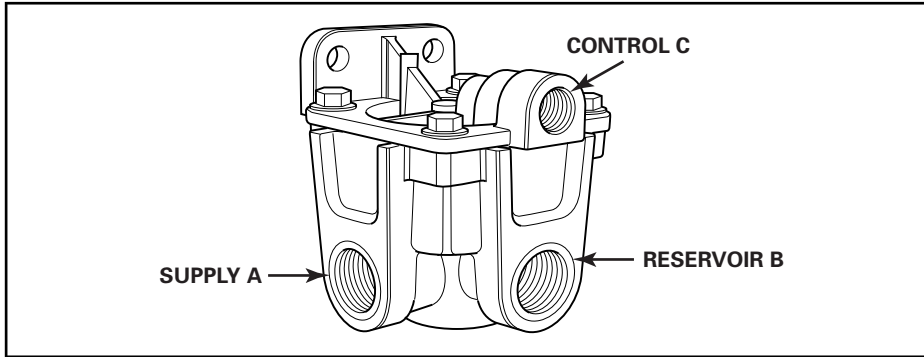

- Meets or exceeds all FMVSS-121 timing requirements.
- Cover may be rotated without affecting performance or warranty.
- One 1/2-inch pipe plug is included.
- All ports are NPTF unless otherwise noted.

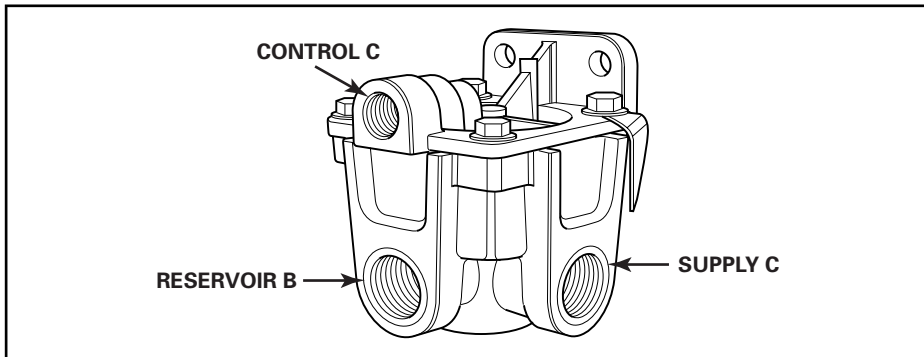

Meritor WABCO		Haldex Brake Systems (Midland)		CONTROL		SUPPLY		DELIVERY				CRACK PRESSURE	COVER POSITION	BRACKET STYLE
SERVICE P/N	OEM P/N	SERVICE P/N	OEM P/N	A	B	C	D	E	F	G	H			
RKN28520	973 298 014 0	KN28520	N30108AH	1/4		1/2	plug	1/2	1/2			6.0 psi	90°	I
RKN28500	973 298 015 0	KN28500	N30108BC	1/4		3/8	3/8	3/8	3/8			6.0 psi	90°	I
RKN28510	973 298 016 0	KN28510	N30108BL	1/4		1/2	plug	3/8	3/8			6.0 psi	90°	I
RKN28500	973 298 022 0	KN28520	N30108A	1/4		1/2	plug	1/2	1/2			6.0 psi	90°	I

# RELAY VALVES

## Service

**MERITOR WABCO**

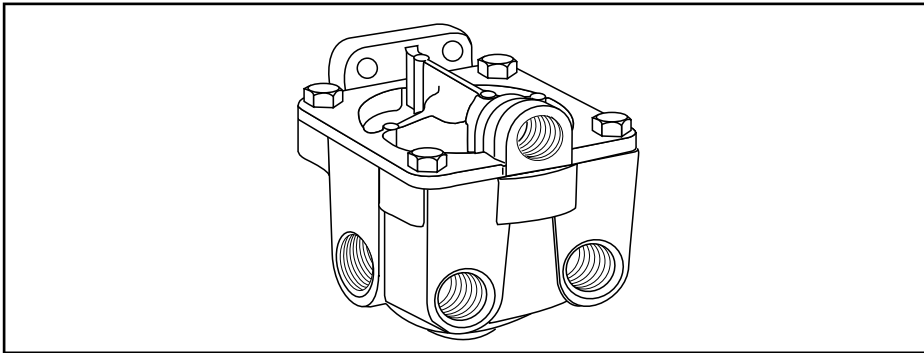

- A multi-purpose, high capacity, straight relay.
- Meets or exceeds all FMVSS-121 timing requirements.
- All ports are NPTF unless otherwise noted.

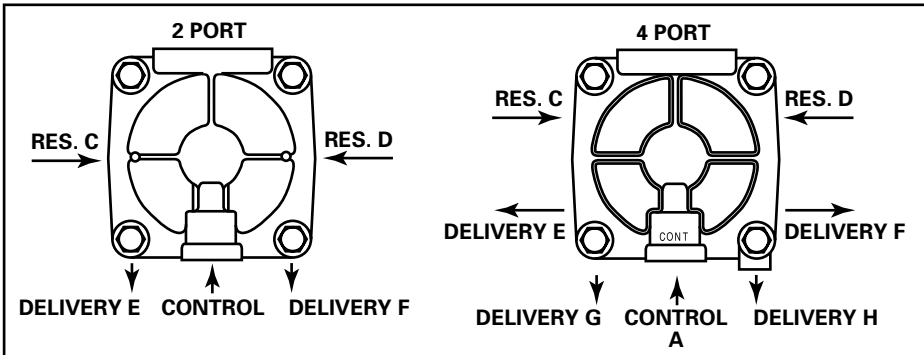

Meritor WABCO		Haldex Brake Systems (Midland)		CONTROL		SUPPLY		DELIVERY				CRACK PRESSURE	COVER POSITION	BRACKET STYLE
SERVICE P/N	OEM P/N	SERVICE P/N	OEM P/N	A	B	C	D	E	F	G	H			
RKN28060	973 298 004 0	KN28060	N30096F	3/8		1/2	1/2	3/8	3/8			4.6 psi	0°	I
RKN28061	973 298 005 0	KN28061	N30096J	3/8		1/2	1/2	1/2	1/2			4.6 psi	180°	I
RKN28061	973 298 006 0	KN28061	N30096L	3/8		1/2	1/2	1/2	1/2			4.6 psi	0°	I
RKN28061	973 298 007 0	KN28061	N30096M	3/8		1/2	plug	3/8	3/8			4.6 psi	0°	I
RKN28080	973 298 008 0	KN28080	N30096N	3/8		1/2	plug	3/8	3/8	3/8	3/8	7.0 psi	0°	I

# RELAY VALVES

## Service

**MERITOR WABCO**

(continued)

Meritor WABCO		Haldex Brake Systems (Midland)		CONTROL		SUPPLY		DELIVERY				CRACK PRESSURE	COVER POSITION	BRACKET STYLE
SERVICE P/N	OEM P/N	SERVICE P/N	OEM P/N	A	B	C	D	E	F	G	H			
RKN28085	973 298 009 0	KN28085	N30096P	3/8		1/2	plug	3/8	3/8	3/8	3/8	4.6 psi	0°	I
RKN28300	973 298 010 0	KN28300	N30096PA	3/8		1/2	1/2	1/2	1/2			0 psi		I
RKN28061	973 298 011 0	KN28061	N30096T	3/8		1/2	1/2	1/2	1/2			7.0 psi	0°	I
RN30106C	973 298 012 0	N30106C	N30106C	1/4		1/2	1/2	1/2	1/2			7.0 psi	270°	A
RKN28131	973 298 013 0	KN28131	N30106F	1/4		1/2	1/2	1/2	1/2			4.0 psi	270°	A
RKN28140	973 298 020 0	KN28140	N30100AP	1/4		1/2	plug	1/2	1/2			4.6 psi	0°	B
RKN28132	973 298 021 0	KN28132	N30106D	3/8		1/2	1/2	1/2	1/2			7.0 psi	0°	I
RKN28066	973 298 035 0	KN28066	N30100JA	1/4		1/2	1/2	1/2	1/2	1/2	1/2	4.6 psi	0°	D
RKN28067	973 298 036 0	KN28067	N30100JB	1/4		1/2	1/2	1/2	1/2	1/2	1/2	4.6 psi	0°	E
RKN28066	973 298 037 0	KN28066	N30100JC	1/4		1/2	1/2	1/2	1/2	1/2	1/2	4.6 psi	0°	F
RKN28066	973 298 038 0	KN28066	N30100JD	1/4		1/2	1/2	1/2	1/2	1/2	1/2	4.6 psi	0°	J
RKN28086	973 298 051 0	KN28086	N30096FA	3/8 PTC		5/8 PTC	5/8 PTC	3/8 PTC	3/8 PTC			4.6 psi	0°	I
RKN28087	973 298 052 0	KN28087	N30096FB	3/8 PTC		5/8 PTC	5/8 PTC	1/2 PTC	1/2 PTC			4.6 psi	0°	I
RKN28088	973 298 053 0	KN28088	N30096FC	3/8 PTC		5/8 PTC	5/8 PTC	3/8 PTC	3/8 PTC	3/8 PTC	3/8 PTC	4.6 psi	0°	I
RKN28089	973 298 054 0	KN28089	N30096FD	3/8 PTC		5/8 PTC	5/8 PTC	1/2 PTC	1/2 PTC	1/2 PTC	1/2 PTC	4.6 psi	0°	I
RKN28085	973 298 056 0	KN28085	N30100JE	1/4		1/2	1/2	1/2	1/2	1/2	1/2	4.6 psi	0°	G
RKN28064	973 298 060 0	KN28064	N30100JF	1/4		1/2	1/2	1/2	1/2	1/2	1/2	4.6 psi	0°	C

PTC = Push-to-Connect fittings

# RELAY VALVES

## Service with Optional Top Port Control

**MERITOR WABCO**

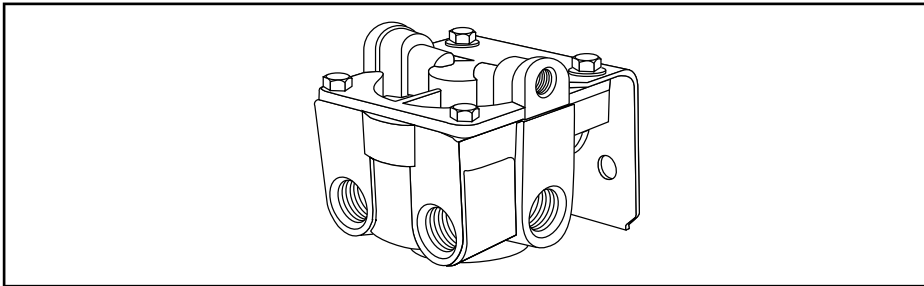

- Meets or exceeds all FMVSS-121 timing requirements.
- Cover may be rotated without affecting performance or warranty.
- All ports are NPTF unless otherwise noted.

**NOTE:** 973 898 005 0 relay valve is NOT illustrated.

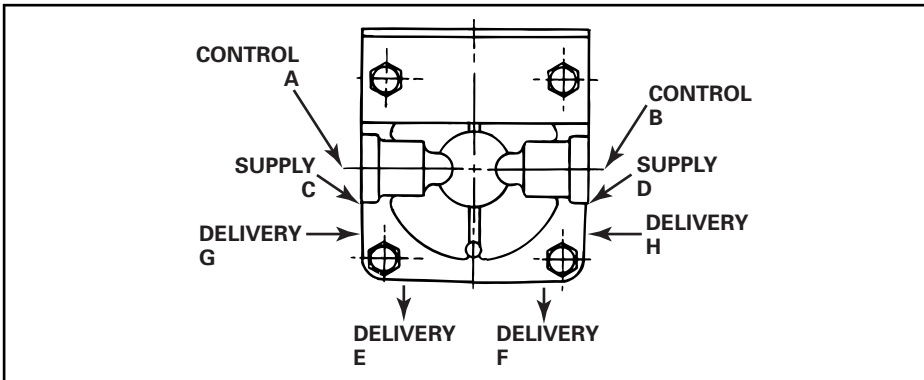

Meritor WABCO		Haldex Brake Systems (Midland)		CONTROL		SUPPLY		DELIVERY				CRACK PRESSURE	COVER POSITION	BRACKET STYLE
SERVICE P/N	OEM P/N	SERVICE P/N	OEM P/N	A	B	C	D	E	F	G	H			
RKN28065	973 898 001 0	KN28065	N30100AR	1/4	1/4	1/2	1/2	1/2	1/2			4.6 psi	90°/270°	B
RKN28140	973 898 005 0	KN28140	N30100AG	1/4	1/4	plug	1/2	1/2	1/2			4.6 psi	270°	B

# RELAY VALVES

## Service with Biased Pressure

**MERITOR WABCO**

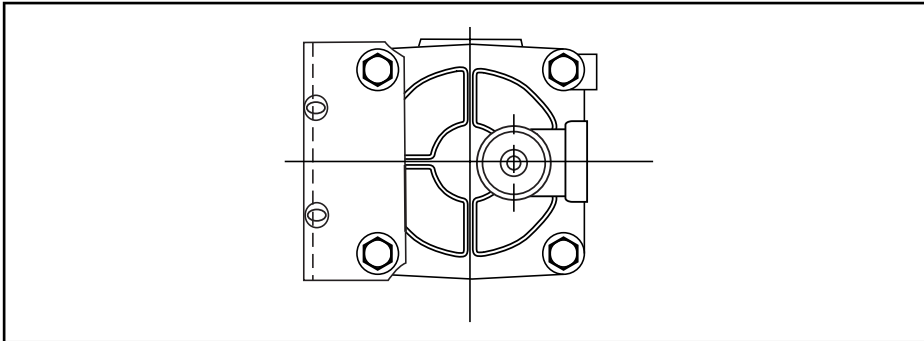
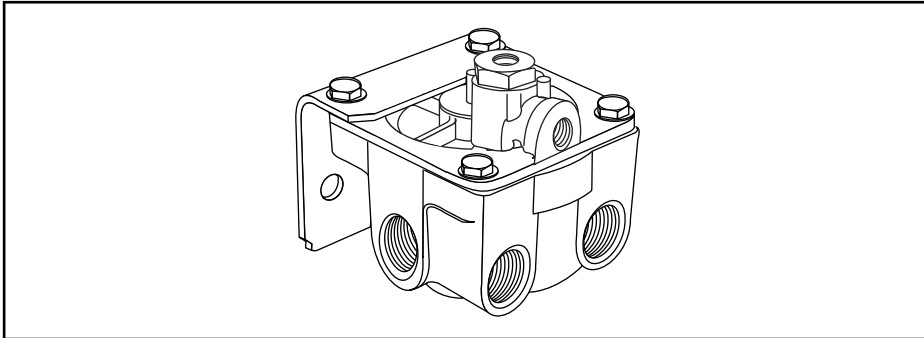

- High capacity.
- Meets or exceeds all FMVSS-121 timing requirements.
- Includes double check valve for truck and bus rear service system.
- Direct replacement for R-12DC.

Meritor WABCO		Haldex Brake Systems (Midland)		CONTROL		SUPPLY		DELIVERY				CRACK PRESSURE	COVER POSITION	BRACKET STYLE
SERVICE P/N	OEM P/N	SERVICE P/N	OEM P/N	A	B	C	D	E	F	G	H			
RKN30111	973 298 031 0	RN30111	N30111	1/4	1/4	1/2	1/2	1/2	1/2	1/2	1/2	Primary control port 4.6 psi	0°	J
RKN28051	973 298 032 0	KN28051	N30111A	1/4	1/4	1/2	1/2	1/2	1/2	1/2	1/2		0°	D
RKN28051	973 298 033 0	KN28051	N30111B	1/4	1/4	1/2	1/2	1/2	1/2	1/2	1/2		0°	E
RKN28052	973 298 034 0	KN28052	N30111C	1/4	1/4	1/2	1/2	1/2	1/2	1/2	1/2		0°	F
RKN28055	973 298 048 0	KN28055	N30111D	1/4	1/4	1/2	1/2	1/2	1/2	1/2	1/2	Secondary control port 9.6 psi	0°	B
RKN28055	973 298 050 0	KN28055	N30111E	1/4	1/4	1/2	1/2	1/2	1/2				0°	B
RKN28053	973 298 057 0	KN28053	N30111F	1/4	1/4	1/2	1/2	1/2	1/2	1/2	1/2		0°	G

# RELAY VALVES

## Spring with Double Check Valve

**MERITOR WABCO**

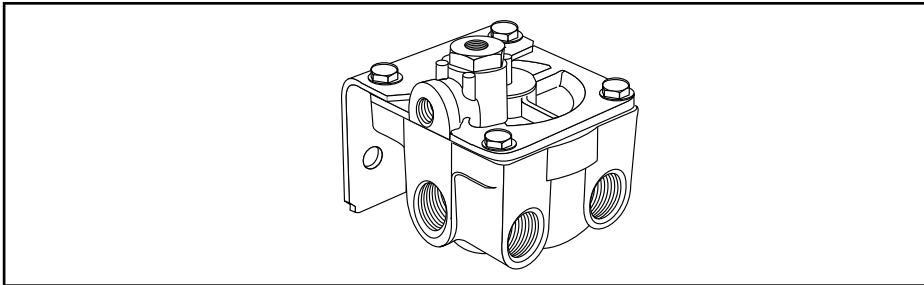

- Low differential — high capacity.
- Meets or exceeds all FMVSS-121 timing requirements.
- Bracket style may be down (as illustrated) or up.
- Includes double check valve for anti-compounding in spring brake system.
- Direct replacement for R-14.

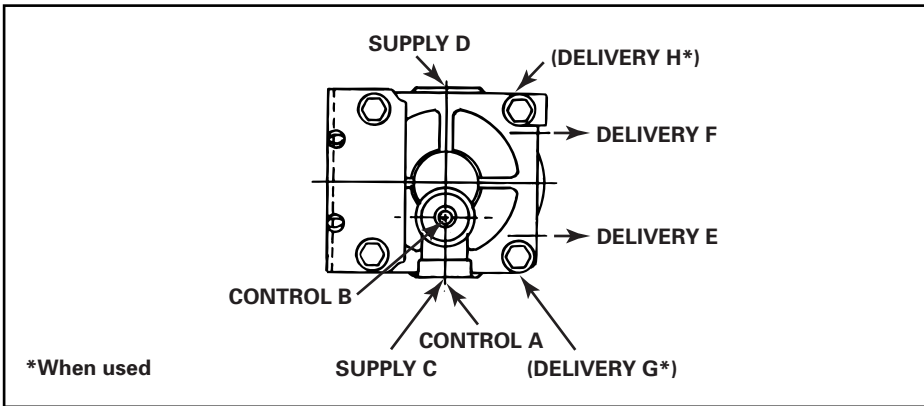

Meritor WABCO		Haldex Brake Systems (Midland)		CONTROL		SUPPLY		DELIVERY				CRACK PRESSURE	COVER POSITION	BRACKET STYLE
SERVICE P/N	OEM P/N	SERVICE P/N	OEM P/N	A	B	C	D	E	F	G	H			
RKN28071	973 298 001 0	KN28071	N30100AD	1/4	1/8	1/2	plug	1/2	1/2			4.6 psi	90°	B down
RKN27502	973 298 017 0	KN27502	N30100LC	3/8 PTC	3/8 PTC	plug	1/2	1/2	1/2			4.6 psi	90°	B down
RKN28072	973 298 040 0	KN28072	N30100KA	1/4	1/8	plug	1/2	1/2	1/2			4.6 psi	90°	B down
RKN28072	973 298 041 0	KN28072	N30100KB	1/4	1/8	1/2	plug	1/2	1/2			4.6 psi	90°	B up
RKN28043	973 298 042 0	KN28043	N30100KC	1/4	1/8	1/2	plug	1/2	1/2			4.6 psi	270°	B down
RKN28073	973 298 043 0	KN28073	N30100KD	1/4	1/8	1/2	plug	1/2	1/2			4.6 psi	90°	E down
RKN28074	973 298 044 0	KN28974	N30100KE	1/4	1/8	1/2	plug	1/2	1/2			4.6 psi	90°	F

# RELAY VALVES

## Spring with Double Check Valve

**MERITOR WABCO**

(continued)

Meritor WABCO		Haldex Brake Systems (Midland)		CONTROL		SUPPLY		DELIVERY				CRACK PRESSURE	COVER POSITION	BRACKET STYLE
SERVICE P/N	OEM P/N	SERVICE P/N	OEM P/N	A	B	C	D	E	F	G	H			
RKN28074	973 298 045 0	KN28074	N30100KF	1/4	1/8	1/2	1/2	1/2	1/2			4.6 psi	90°	H
RKN28073	973 298 046 0	KN28073	N30100KG	1/4	1/8	1/2	plug	1/2	1/2			4.6 psi	90°	E
RKN28074	973 298 047 0	KN28074	N30100KH	1/4	1/8	1/2	1/2	1/2	1/2			4.6 psi	270°	J
RKN28041	973 298 055 0	KN28041	N30100MA	1/4	1/8	1/2	plug	1/2	1/2	1/2	1/2	4.6 psi	270°	B
RKN28069	973 298 058 0	KN28069	N30100MB	1/4	1/4	1/2	1/2	3/8	3/8	3/8	3/8	4.6 psi	0°	G
RKN28063	973 298 061 0	KN28063	N30100MC	1/4	1/4	1/2	1/2	3/8	3/8	3/8	3/8	4.6 psi	0°	C
RKN28140	973 898 006 0	KN28071	N30100HH	1/4	1/8	1/2	1/2	1/2	1/2			4.6 psi	0°	I

PTC = Push-to-Connect fittings

# TRACTOR PROTECTION VALVES

## Tractor Protection Valves Two-Line

**MERITOR WABCO**

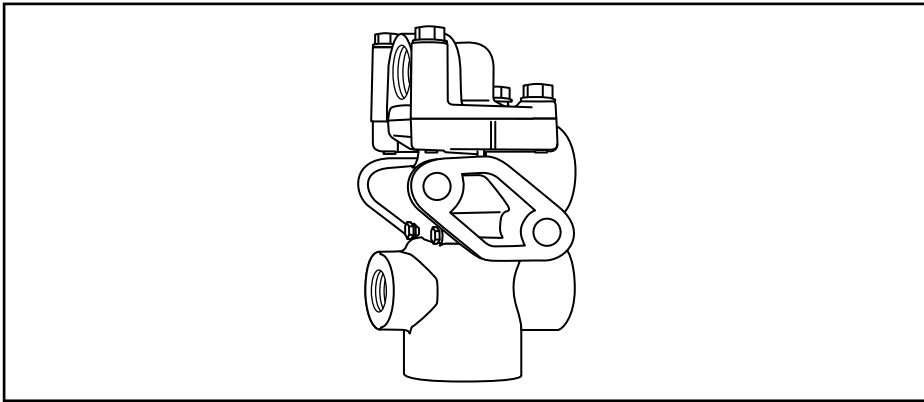

- Two-line non-automatic.
- **Must be used with pressure sensing dash control valve.**
- Quick release feature eliminates the need for an extra valve.
- Will not allow trailer brake compounding.
- Direct replacement for the TP-3 valve.
- All ports are NPTF unless otherwise noted.

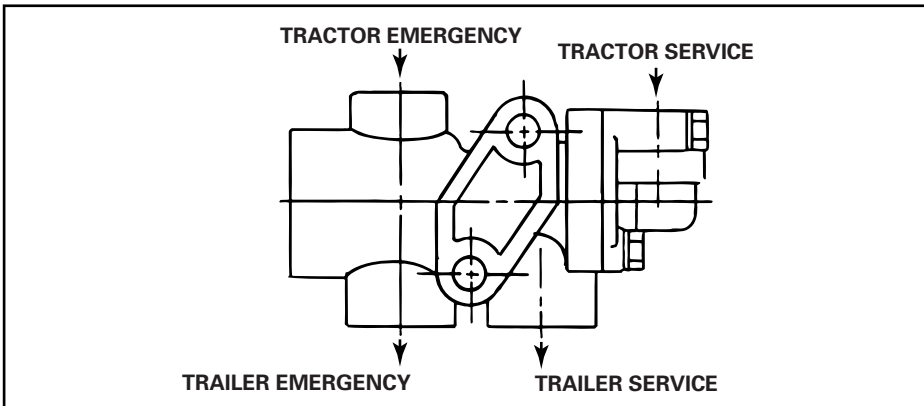

Meritor WABCO		Haldex Brake Systems (Midland)		TRACTOR SERVICE	TRACTOR EMERGENCY	TRAILER SERVICE	TRAILER EMERGENCY
SERVICE P/N	OEM P/N	SERVICE P/N	OEM P/N				
RKN34061	934 899 002 0	KN34061	N20949CF	3/8	1/4	1/2	1/2
RKN34060	934 899 011 0	KN34060	N20949CA	3/8	1/4	1/2	1/2
RKN34065	939 899 029 0	KN34065	N20949DA	3/8 PTC	3/8 PTC	1/2	1/2

PTC = Push-to-Connect fittings



# TRACTOR PROTECTION VALVES

## Tractor Protection Valves Two-Line (Manifold Style)

**MERITOR WABCO**

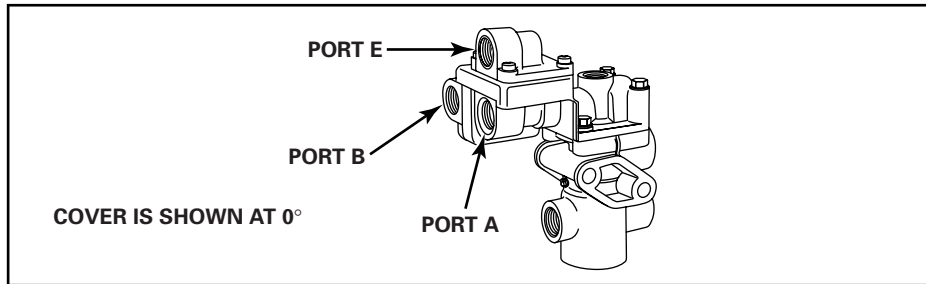

- Includes: tractor protection, two double check valves, stoplight switch port, and built-in quick release, all in one valve.
- Can replace up to four valves on competitive systems.
- All ports are NPTF unless otherwise noted.

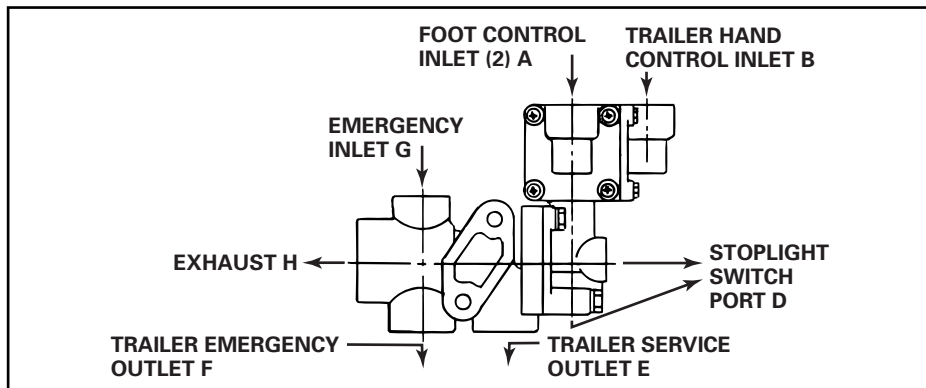

Meritor WABCO		Haldex Brake Systems (Midland)		PORTS							EXHAUST FITTINGS (H)	REMARKS	COVER POSITION
SERVICE P/N	OEM P/N	SERVICE P/N	OEM P/N	A	B	C	D	E	F	G			
RKN34110	934 899 003 0	KN34110	N30162MA	3/8	3/8	3/8	1/4	1/2	1/2	3/8	YES	TRAC. EM 3/8	0°
RKN34110	934 899 009 0	KN34110	N30162PA	3/8	3/8	3/8	1/4	1/2	1/2	1/2	YES	TRAC. EM 3/8	0°
RKN34130	934 899 010 0	KN34130	N30162PC	3/8	3/8	3/8	1/4	1/2	1/2	3/8	YES	—	180°
RKN34100	934 899 020 0	KN34100	N30162NA	3/8	3/8	3/8	1/4	3/8	3/8	3/8	NO		0°
RKN34111	934 899 022 0	KN34111	N30162ME	3/8	3/8	3/8	1/4	1/2	1/2	3/8	NO		0°
RKN34103	934 899 025 0	KN34103	N30162PB	3/8	3/8	3/8	1/4	1/2	1/2	1/2	YES	Navistar application	Special
RKN34104	934 899 028 0	KN34104	N30162PD	3/8	3/8	3/8	1/4	1/2	1/2	3/8	YES		0°
RKN34101	934 899 030 0	KN34101	N30162RD	1/2 PTC	3/8 PTC	3/8 PTC	1/4	1/2	1/2	3/8 PTC	NO		0°

PTC = Push-to-Connect fittings

# TRACTOR PROTECTION VALVES

## Tractor Protection Valves Three-Line

**MERITOR WABCO**

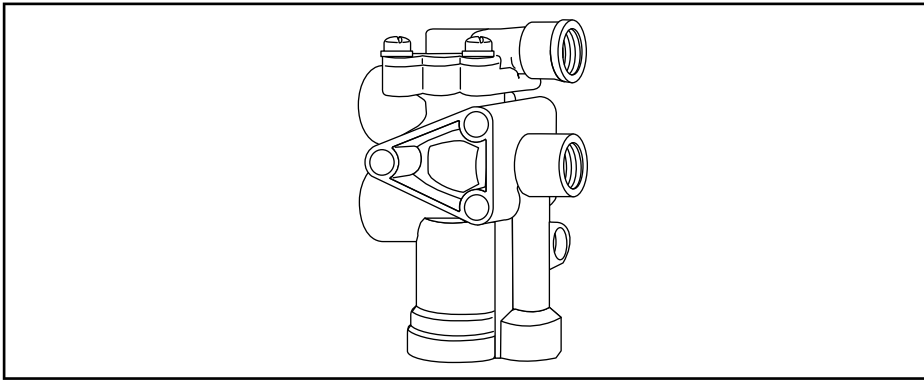

- Three-line automatic tractor protection with quick release.
- Can replace two valves on some competitive systems.
- Available with standard thread fittings.
- All ports are NPTF unless otherwise noted.

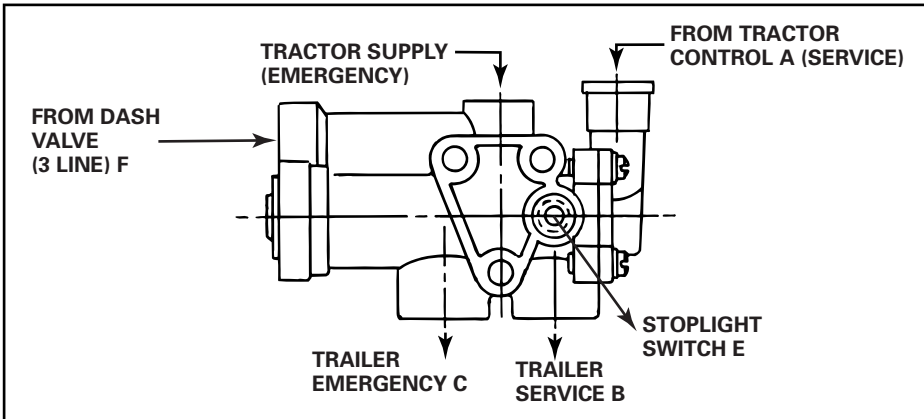

Meritor WABCO		Haldex Brake Systems (Midland)		TYPE	PORTS						REMARKS
SERVICE P/N	OEM P/N	SERVICE P/N	OEM P/N		A	B	C	D	E	F	
RKN34071	934 899 017 0	KN34071	N30073GE	3-Line	3/8	1/2	1/2	3/8	1/8	1/4	—

# ACCESSORIES — ELECTRICAL

## Electro-Pneumatic Switches

**MERITOR WABCO**

### PARK BRAKE SWITCH

- Actuates at 55 psi.
- Single pole, two terminal design.
- Circuit normally closed at 0 pressure.

Meritor WABCO		Haldex Brake Systems (Midland)	
SERVICE P/N	OEM P/N	SERVICE P/N	OEM P/N
RBE13240	894 041 608 2	BE13240	13240A

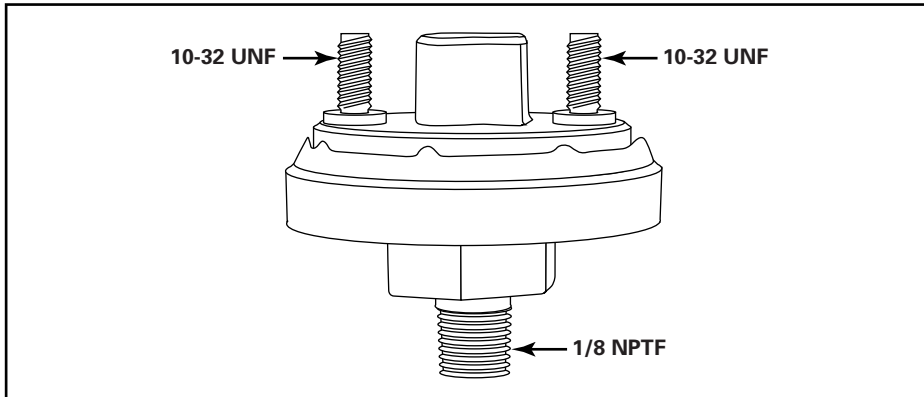

### LOW AIR SWITCH

- Actuates at 70 ± 5 psi.
- Single pole, two terminal design.
- Circuit normally closed at 0 pressure.

Meritor WABCO		Haldex Brake Systems (Midland)		REMARKS
SERVICE P/N	OEM P/N	SERVICE P/N	OEM P/N	
R13241A	894 041 606 2	BE13241	13241A	
RBE13241	894 041 609 2	BE13241	1324150	
R1324150	894 041 615 2	1324150	1324150	
RN15364G*	894 041 621 2	BE13241	N15364G	Western Star application

\* with nuts

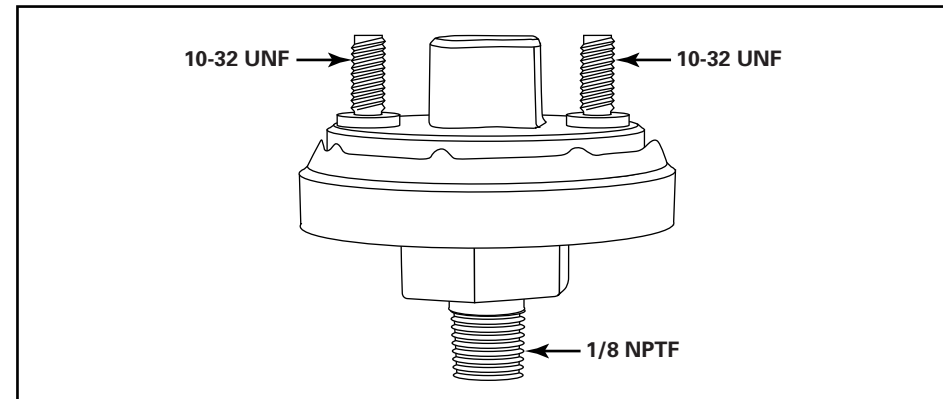

# ACCESSORIES — ELECTRICAL

## Electro-Pneumatic Switches

**MERITOR WABCO**

### SERVICE CIRCUIT STOPLIGHT SWITCH

- Actuates at 3-5 psi.
- Single pole, two terminal design.
- Circuit normally open at 0 pressure.
- Solid state contacts.
- Snap action design to increase switch life.
- Tested at one million cycles at 30 Amps.

Meritor WABCO		Haldex Brake Systems (Midland)	
SERVICE P/N	OEM P/N	SERVICE P/N	OEM P/N
RBE13250*	894 041 605 2*	BE13250	3250
R325010	894 041 607 2	325010	325010
RBE13250	894 041 610 2*	BE13250	325011

\* with nuts

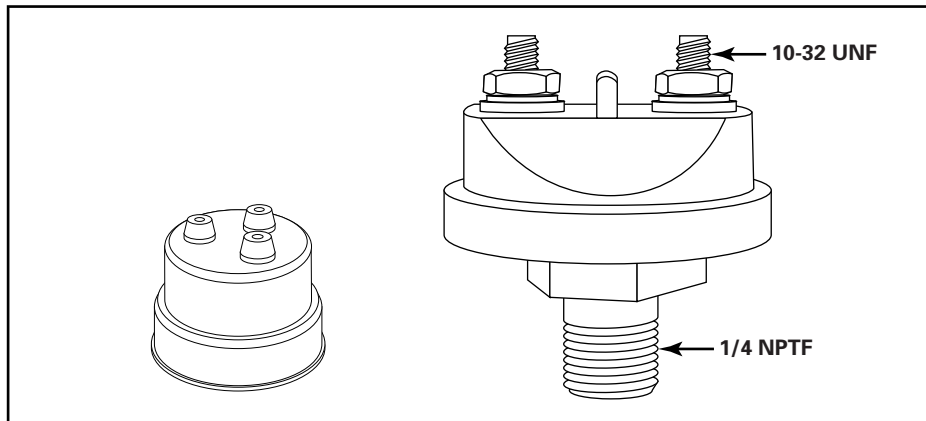

### TRAILER EMERGENCY STOPLIGHT SWITCH

- Actuates at 55 psi.
- Single pole, double throw, three-terminal design.
- Circuits normally one open, one closed.

Meritor WABCO		Haldex Brake Systems (Midland)	
SERVICE P/N	OEM P/N	SERVICE P/N	OEM P/N
RBE13255	894 041 612 2	BE13255	13255A
R1325550*	894 041 616 2*	1325550	1325550
R300629A**	894 041 619 2**	300629A	300629A
RBE13255	894 041 620 2	BE13255	N15364F

\* with nuts

\*\* with pigtail connector

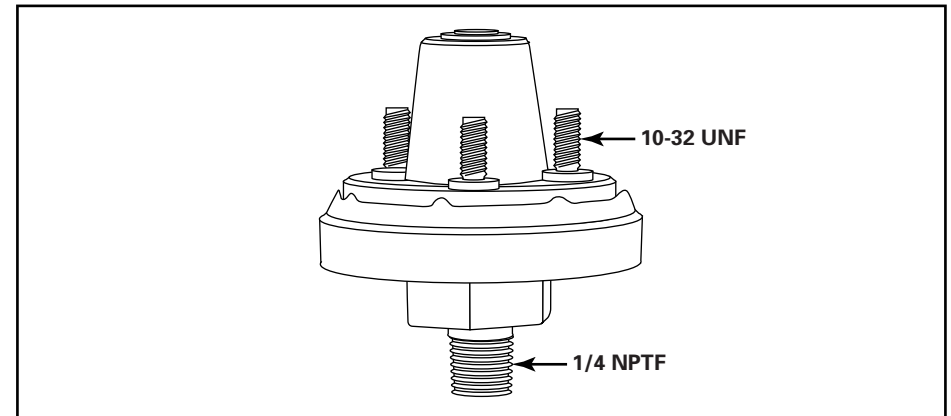

# ACCESSORIES

## Bulkhead Fitting (Frame Nipple)

**MERITOR WABCO**

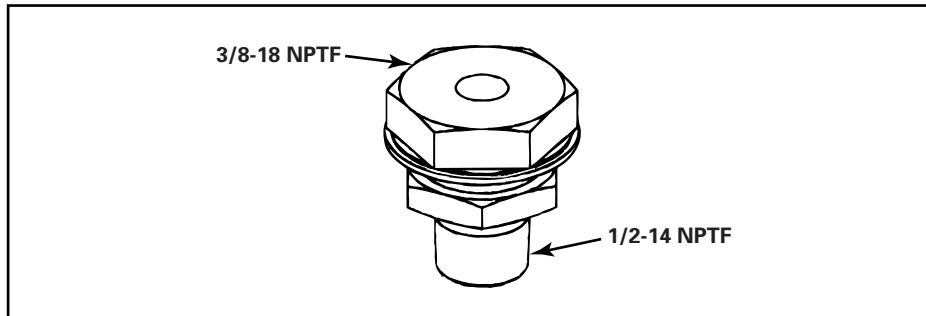

Meritor WABCO		
SERVICE P/N	OEM P/N	DESCRIPTION
S893 891 003 2	893 891 003 2	Frame Nipple

## In-Line Filters

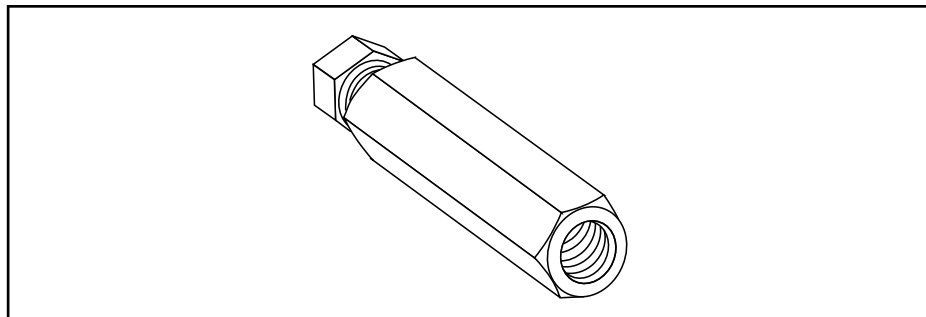



Meritor WABCO		Haldex Brake Systems (Midland)		
SERVICE P/N	OEM P/N	SERVICE P/N	OEM P/N	DESCRIPTION
RKN31026	899 381 282 4	KN31026	N10083F	2 female ports (1/4" ports)
RN10083K	899 381 283 4	KN31025	N10083K	1 female port, 1 male port (1/4" ports)

# ACCESSORIES

## Knobs

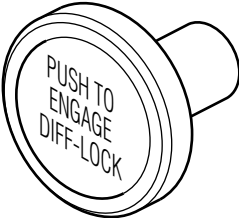
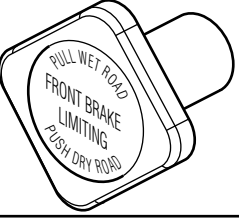
**MERITOR WABCO**

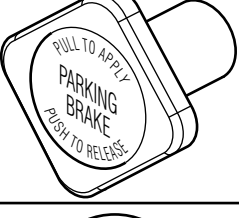
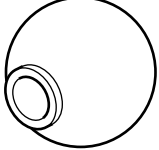
	Meritor WABCO		Haldex Brake Systems (Midland)		REMARKS
	SERVICE P/N	OEM P/N	SERVICE P/N	OEM P/N	
	<b>R102684A</b>	936 649 671 4	<b>102684-A</b>	102684-A	Dash Control, 1/4-28 UNF, Black body
	<b>R1155903</b>	936 649 672 4	<b>1155903</b>	1155903	Front Brake Limiting (wet road), 1/4-28 UNF, Yellow body
	<b>R12503</b>	936 649 673 4	<b>12503</b>	1175003	Park, 1/4-20 UNF, Yellow body
	<b>R12509</b>	936 649 674 4	<b>12509</b>	1175013	Park, 1/4-28 UNF, Black body
	<b>RN15285P</b>	936 649 678 4	<b>N15285P</b>	N15285P	5/16-24 UNF, Black body

# ACCESSORIES — TREADLES

## Aluminum Treadles

**MERITOR WABCO**

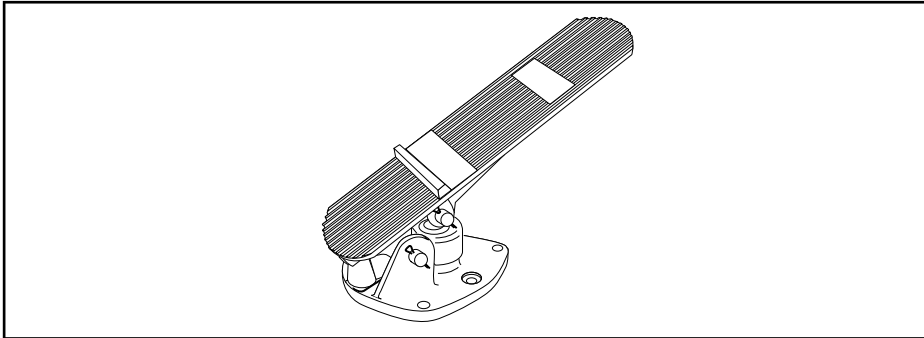

### ALUMINUM TREADLE FOR BRAKE APPLICATION VALVES

- A lightweight, strong pedal for brake application valves.
- Logo is cast in pedal surface — won't wear off.
- Replaces most steel pedals on today's vehicles.
- Interchanges with most competitive models.

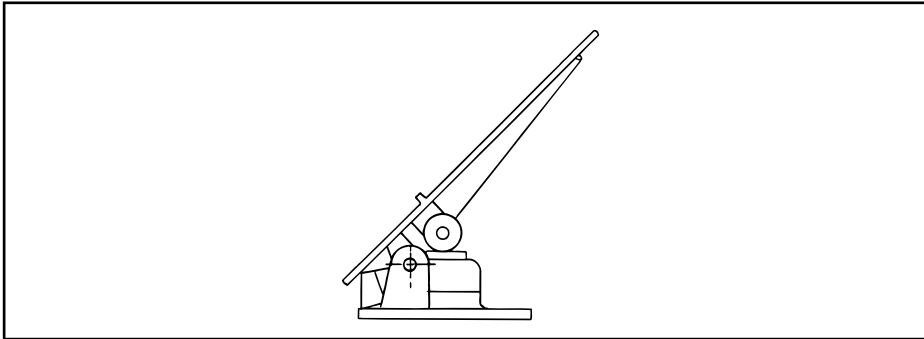

Meritor WABCO		Haldex Brake Systems (Midland)		PEDAL ANGLE	REMARKS
SERVICE P/N	OEM P/N	SERVICE P/N	OEM P/N		
RSN4017E	961 899 710 2	SN4017E	N30056BX	34°	—
RSN4017A	961 899 711 2	SN4017A	N30056BL	50°	International Truck application
RSN4017A	961 899 712 2	SN4017A	N30056BR	45°	—
RSN4017F	961 899 713 2	SN4017F	N30056BW	27°	—
RSN4017A	961 899 714 2	SN4017A	N30056CB	50°	—
RKN21051	961 899 715 2	KN21051	N21051	—	Plate only
RN21052	961 899 716 2	N21052	N21052	—	Treadle only. Mack application
RSN4017A	961 899 718 2	SN4017A	N30056BK	41°	—

**ArvinMeritor™**

**Meritor WABCO**  
Vehicle Control Systems  
3331 West Big Beaver Road, Suite 300  
Troy, MI 48084 USA  
800-535-5560  
meritorwabco.com



Information contained in this publication was in effect at the time the publication was approved for printing and is subject to change without notice or liability. Meritor WABCO reserves the right to revise the information presented or discontinue the production of parts described at any time.

Copyright 2002  
ArvinMeritor, Inc.  
All Rights Reserved

Printed in the USA

PB-9926  
Revised 12-02  
16579/24240